

1
2
3
4
5
6
7
8
9
10
11
12
13
14
15
16
17
18
19
20
21
22
23
24
25
26
27
28
29
30
31
32
33
34
35
36
37
38
39
40
41
42
43
44
45
46

CHAPTER 16
SUBDIVISION REGULATION ORDINANCE

~~[Adopted eff. 6/9/68, under R. S. 1964, T. 30, Sec. 4956] (With revisions eff. 7/13/93 and subsequent revisions eff. 2/12/94, 7/13/94, 1/10/96 and 12/10/03)~~

Article I.	Purpose, Authority, Scope, Definitions	1
Sec. 16-1-1.	Purpose	1
Sec. 16-1-2.	Authority	3
Sec. 16-1-3.	Scope	3
Sec. 16-1-4.	Definitions	3
Article II.	Review Procedures	6
Sec. 16-2-1.	General Procedures	6
Sec. 16-2-2.	Pre-Application Process	6
Sec. 16-2-3.	Review & Approval of Minor Subdivision Plans	6
Sec. 16-2-4.	Review & Approval of Major Subdivision Plans	8
Sec. 16-2-5.	Amendments to Previously Approved Subdivision Plans	14
Sec. 16-2-6.	Inspection of Required Improvements	14
Article III.	Standards	16
Sec. 16-3-1.	General Standards of Subdivision Design	16
Sec. 16-3-2.	Road Design & Construction Design	20
	<u>Road Classification Standards Table</u>	
Sec. 16-3-3.	Design of Other Improvements	35
Sec. 16-3-4.	Additional Standards	36
Sec. 16-3-5.	Waivers	36
Sec. 16-3-6.	Legal Provisions	36
Appendix A.	<u>Minor Subdivision Submission list</u>	37
Appendix B.	<u>Major Subdivision Submission list</u>	40
Appendix C.	<u>Road Tree List</u>	44
Appendix D.	<u>Turnaround designs</u>	
Appendix E.	<u>Road Design Cross Sections</u>	

ARTICLE I. Purpose, Authority, Scope, Definitions.

Sec. 16-1-1. Purpose. This Ordinance is designed to promote the health, safety, convenience and general welfare of the Inhabitants of the Town of Cape Elizabeth by encouraging and ensuring sound planning, the use of the environment under healthful conditions, the imaginative and orderly use of land, compliance with the goals and objectives of the Comprehensive Plan, and development that fits harmoniously into the existing natural environment and rural character. ~~To this end, in evaluating any proposed subdivision of land within the Town of Cape Elizabeth, the Planning Board shall determine whether such subdivision will meet the standards set forth in this Chapter and:~~

- 1 ~~(a) Will not result in undue water or air pollution. In making this determination it~~
2 ~~shall consider at least: the elevation of land above sea level and its relation to the~~
3 ~~flood plains, the nature of soils and sub-soils and their ability too adequately~~
4 ~~support waste disposal; the slope of the land and its effect on effluents; the~~
5 ~~availability of streams for disposal of effluents; and the applicable state and local~~
6 ~~health and water resources regulations;~~
7
8 ~~(b) Has sufficient water available for the reasonably foreseeable needs of the~~
9 ~~subdivision;~~
10
11 ~~(c) Will not cause an unreasonable burden on an existing public water supply, if one~~
12 ~~is to be utilized;~~
13
14 ~~(d) Will not cause an unreasonable soil erosion or reduction in the capacity of the~~
15 ~~land to hold water so that a dangerous or unhealthy condition may result;~~
16
17 ~~(e) Will not cause unreasonable highway or public road congestion or unsafe~~
18 ~~conditions with respect to use of the highways or public roads, alone or in~~
19 ~~conjunction with existing or contemplated road use;~~
20
21 ~~(f) Will provide for adequate sewage waste disposal;~~
22
23 ~~(g) Will not cause an unreasonable burden on the ability of a municipality to dispose~~
24 ~~of solid waste and sewage if municipal services are to be utilized;~~
25
26 ~~(h) Will not have an undue adverse effect on the scenic or natural beauty of the area,~~
27 ~~scenic vistas, aesthetics, wildlife habitat, historic sites or rare and irreplaceable~~
28 ~~natural areas; or any public rights for physical or visual access to the shoreline;~~
29
30 ~~(i) Is in conformance with these Subdivision Regulations, the Zoning Ordinance,~~
31 ~~Comprehensive Plan for the Town of Cape Elizabeth and the requirements for~~
32 ~~building and development in flood hazard areas set forth in Article VI of Chapter~~
33 ~~6 of this Code of Ordinances;~~
34
35 ~~(j) The applicant has adequate financial and technical capacity to meet the above~~
36 ~~stated standards;~~
37
38 ~~(k) Whenever situated, in whole or in part, within 250 feet of any water body, stream,~~
39 ~~brook, wetland as defined in the Zoning Ordinance, or tidal waters, will not~~
40 ~~adversely affect the quality of such body of water or unreasonably affect the~~
41 ~~shoreline of such body of water;~~
42
43 ~~(l) Will not, alone or in conjunction with existing activities, adversely affect the~~
44 ~~quality of ground water;~~
45

1 ~~(m) The applicant will determine, based on the Federal Emergency Management~~
2 ~~Agency's Flood Boundary and Floodway Maps and Flood Insurance Rate Maps,~~
3 ~~whether the subdivision is in a flood-prone area. If the subdivision, or any part of~~
4 ~~it, is in such an area, the applicant will determine the 100-year flood elevation and~~
5 ~~flood hazard boundaries within the subdivision. The proposed subdivision plan~~
6 ~~shall include a condition of plat approval requiring that principal structures on lots~~
7 ~~in the subdivision shall be constructed with their lowest floor, including the~~
8 ~~basement, at least one foot above the 100-year flood elevation; and~~

9
10 ~~(n) Will promote energy conservation and efficiency.~~

11 **Sec. 16-1-2. Authority.** ~~These regulations~~ This Ordinance shall apply to all land within
12 the limits of the Town of Cape Elizabeth, Cumberland County, Maine. ~~They and~~ shall be
13 administered by the Planning Board of the Town of Cape Elizabeth, hereinafter called
14 "the Planning Board", and the Town's ~~designated code enforcement staff, and the~~
15 ~~registered professional engineer employed or retained by the Town who shall be its~~
16 ~~lawful agents.~~

17 **Sec. 16-1-3 Scope.**

- 18
19 (a) Any person, firm, corporation or other legal entity proposing to sell, lease or
20 convey, or to offer or agree to sell, lease or convey, any land in a subdivision any
21 portion of which is within the limits of the Town of Cape Elizabeth, ~~including~~
22 ~~without limitation any unit within multiplex housing, as defined herein,~~ shall first
23 submit such subdivision for approval by the Planning Board in accordance with
24 ~~these Regulations Ordinance~~ and shall record in the Cumberland County
25 Registry of Deeds a plan thereof bearing the approval of the Planning Board.
26
27 (b) No utility installations; no ditching, grading or construction of roads; no grading
28 of land or lots; and no construction of buildings shall be done on any part of the
29 proposed subdivision until a subdivision application has been submitted, reviewed
30 and finally approved as provided by this Ordinance.

31
32 **Sec. 16-1-4 Definitions.**

33
34 In general, words and terms used in this Ordinance ~~these Regulations~~ shall have their
35 customary dictionary meanings, but the following words and terms as used in this
36 ~~Ordinance~~ ~~these Regulations~~ are defined as follows:

37 "Applicant" - the record owner, or a person having an interest in the land either through
38 written option or contract.

39 "Access Road" - any road which includes (1) an eighteen (18) feet² wide traveled way,
40 (2) deeded and actual rights of public emergency access, and (3) year-round maintenance,
41 including snow plowing of the road, the responsibility of which is documented in a
42 binding written agreement if the road is not located within a public right-of-way.

1 “**Arterial**” - a road which is a major link with other communities. This road typically
2 averages in excess of three thousand (3,000) trips per day with an average length of each
3 trip of more than one mile. Arterials accommodate residential, agricultural and most of
4 the Town’s commercial development. Direct access by residential development should be
5 discouraged, and commercial access should be combined with adjacent commercial uses
6 where feasible.

7 “AASHTO” - the American Association of State Highway and Transportation Officials,
8 an organization that establishes transportation specifications.

9 ~~“Board” - shall refer to Planning Board.~~

10 “**Building Envelope**” - ~~t~~The area within a lot where the main and accessory buildings
11 shall be located.

12 “**Cluster Development**” - ~~a~~A type of subdivision development for single family
13 detached dwellings, ~~or a combination of single family detached dwellings and~~ multiplex
14 dwellings, or a combination of both, where lot sizes, lot widths, and building setbacks are
15 reduced below the minimum requirements of this Oerdinace and the land gained thereby
16 is set aside as open space.

17 ~~“Code Enforcement Administrator” - the staff person designated to administer the~~
18 ~~Town’s code enforcement operations.~~

19 “**Collector**” - a road ~~that~~which collects traffic from the most densely settled areas and
20 typically connects to an adjacent community. This road averages in excess of two
21 thousand (2,000) trips per day with an average length of each trip over more than one
22 mile. Collectors are located in areas with a dense, suburban pattern of development. The
23 design of collectors must provide heavy traffic flow capacity and protect sensitive scenic
24 areas and neighborhoods. Direct access by single driveway should be discouraged.

25 “**Dead-end road**” - a road with a single, common means of ingress and egress.
26 [Rev. eff. 7/13/94]

27
28 “**Ditch**” - a channel for conveying surface water outside the traveled way.

29
30 “Dwelling unit” - any part of a structure which, through sale or lease, is intended for
31 human habitation, including single-family and multi-family housing, condominiums,
32 apartments and time-share units.

33
34 “Easement”- a grant of one or more of the property rights by the property owner to
35 and/or for use by the public, a corporation, or another person or entity. Examples of
36 easements include but are not limited to drainage, conservation, emergency access,
37 pedestrian, utility, road and open space easements.

38
39 “**Emergency Access Lane**”- a public or private paved road with a minimum width of
40 eighteen (18) feet² which is not open to through vehicular traffic. This type of road may
41 provide secondary emergency access to an area served by a dead-end road. [Rev. eff.
42 6/12/91]

1 “**Esplanade**” - a landscaped strip of land located between a road and a sidewalk or
2 between two roads.

3 “**Farmland**” - a parcel consisting of five (5) or more acres of land that is (1) classified as
4 prime farmland, unique farmland or farmland of statewide or local importance by the
5 Natural Resources Conservation Service within the United States Department of
6 Agriculture; or (2) used for the production of agricultural products as defined in Title 7
7 M.R.S.A. Sec. 152, subsection 2.

8 “**Feeder**” - a road ~~that~~which connects local roads to other roads. This road is typically
9 densely developed and serves more than one-hundred (100) dwellings or approximately
10 one-thousand (1,000) trips per day. Feeders primarily serve residential traffic where
11 access by single driveway is common.

12 ~~“**Final Approval**” - The status of an application once there has been a Planning Board~~
13 ~~Decision, any conditions on the approval have been met, the recording plat has been~~
14 ~~signed and a performance guarantee has been accepted by the Town.~~

15 ~~“**Gutter**” - a channel for conveying surface water along the edge of pavement.~~

16 “**Local Road**” - a road ~~that~~which provides direct access to adjacent residential land or
17 the Town center area. The local road is the most common road classification and carries a
18 low volume of trips in residential areas, although higher volumes are also common in the
19 Town center area. Local roads should be designed for slow speeds and frequent
20 pedestrian travel.

21 “**Lot**” - an area of land in one ownership, regardless of the dates or sources of acquisition
22 thereof and regardless of the buildings and uses existing thereon, having definite
23 boundaries by recorded plan or deed and having an area of less than forty (40) acres.

24 “**Manufactured Housing Unit**” - structures, transportable in one or ~~two~~more sections,
25 which were constructed in a manufacturing facility and are transported to a building site
26 and designed to be used as dwellings when connected to the required utilities, including
27 the plumbing, heating, air conditioning and electrical systems contained therein.

28 “**Manufactured Housing Park**” - a parcel of land under unified ownership designed
29 and/or used to accommodate three or more manufactured housing units.

30 “**Manufactured Housing Park Lot**” - the area of land on which an individual home is
31 situated within a manufactured housing park and which is reserved for use by the
32 occupants of that home.

33 “**MDOT**” - The State of Maine Department of Transportation.

34 “**M.R.S.A**” - Maine Revised Statutes Annotated.

35 “**MUTCD**” - The Manual on Uniform Traffic Control Device Standards.

36 “**Multiplex Housing**” - attached dwelling units, as defined in the Zoning Ordinance
37 (Chapter 19).

38 “**Performance Guarantee**” - any security that may be accepted by the Town to assure
39 that improvements required as part of an application for development will be completed
40 in compliance with the approved plans.

1 | **“Planner”** - that person designated ~~from time to time~~ by the Town to assist the Planning
2 | Board in its subdivision and site plan review.

3 | **“Planning Board Decision”** - the Planning Board vote to approve or conditionally
4 | approve the preliminary or final plan.

5 | **“Principal Structure”** - any building other than one ~~that which~~ is used for purposes
6 | wholly incidental or accessory to the use of another building on the same premises.

7 | **“Private Road”** - a road or way ~~that which~~ provides access to more than one principal
8 | structure and which is not owned by the Town.

9 | **“Resubdivision”** - the replatting of all or part of the land included in a subdivision plan
10 | already approved by the Planning Board.

11 | **“Right-of-way”**- (1) a strip of land acquired by conveyance, reservation, dedication,
12 | forced dedication, prescription or condemnation and intended to be occupied by a road,
13 | sidewalk, crosswalk, railroad, electric transmission lines, oil or gas pipeline, water line,
14 | sanitary storm sewer, or other similar uses; (2) generally, the right of one to pass over the
15 | property of another.

16 | **“Road”** - a public or private way for vehicular traffic however designated, serving more
17 | than one residential unit or more than one lot.

18 | **“Rural Connector”** - ~~a~~A road ~~that which~~ handles trips between different parts of Town
19 | and connects rural residential development to arterials. This road typically carries less
20 | than (1,000) trips per day with an average length of more than one (1) mile. Rural
21 | connectors are located in primarily rural residential areas and the rural character should
22 | be maintained. Access by residential ~~7~~development should preferably be by a local road,
23 | but may be from a single driveway.

24 | **“Sight Distance”** - ~~see continuous and clear sight distance that meets the minimum~~
25 | ~~requirements in~~ Section 16-3-2 (a) (1) of this Ordinance.

26 | **“Site Improvement”** - all changes and construction required of a
27 | ~~development~~subdivision to be in compliance with Planning Board approval and Town
28 | Standards.

29 | **“Spaghetti lot”** - any lot in a proposed subdivision with shore frontage on a river,
30 | stream, brook, great pond, or coastal wetland, as these features are defined in Title 38
31 | M.R.S.A. Section 480(B), with a lot depth to shore frontage ratio greater than 5 (five) to
32 | 1 (one).

33 | **“Standard Boundary Survey”** - a map of a quantity of real estate prepared by a
34 | professional land surveyor registered in the State of Maine and based on (1) adequate
35 | research to support a professional opinion of boundary location, (2) field work including
36 | an inspection of the real estate and (3) the preparation of a plan, drawn to scale and
37 | including property boundary lines, easements and rights-of-way and existing structures,
38 | suitable for recording.

39 |

40 | **“Structure”** - anything constructed or erected with a fixed location on or in the ground,
41 | or attached to something having a fixed location on or in the ground, including, but not
42 | limited to, buildings, mobile homes, retaining walls, billboards, signs, piers and floats. It

1 does not include a wharf, fish weir or trap that may be licensed under Title 38 M.R.S.A.
2 Sections 1021-1027. A new structure or structures includes any structures for which
3 construction begins on or after September 23, 1988. The area included in the expansion
4 of an existing structure is deemed to be a new structure for the purposes of the
5 Subdivision Ordinance.

6 **“Subdivision”** - the division of a tract or parcel of land into three (3) or more lots within
7 any five (5) year period, which period begins after September 22, 1971, whether
8 accomplished by sale, lease, development, buildings or otherwise. The term
9 “subdivision” also includes the division of a new structure or structures on a tract or
10 parcel of land into three (3) or more dwelling units within a five (5) year period, the
11 construction or placement of three (3) or more dwelling units on a single tract or parcel of
12 and the division of an existing structure or structures previously used for commercial or
13 industrial use into three (3) or more dwelling units within a five (5) year period, provided
14 that a division accomplished by devise, condemnation, order of court, gift to a person
15 related to the donor by blood, marriage or adoption, unless the intent of such gift is to
16 avoid the objectives of this Ordinance, or by transfer of any interest in land to the owner
17 of land abutting thereon, shall not be considered to create a lot or lots for the purpose of
18 this Ordinance.

19 A. In determining whether a tract or parcel of land is divided into three (3) or more
20 lots, the first dividing of such tract or parcel, ~~unless otherwise exempted herein,~~
21 ~~shall be~~ is considered to create the first two (2) lots and the next dividing of
22 either of said first two lots, by whomever accomplished, ~~unless otherwise~~
23 ~~exempted herein,~~ shall be is considered to create a third-3rd lot, unless:

24 (1) ~~Both such~~ dividings are accomplished by a ~~applicant~~ subdivider who has
25 ~~shall have~~ retained one of ~~thesuch~~ lots for ~~his~~ the subdivider’s own use as a
26 single family residence for a period of at least five (5) years ~~prior to such~~
27 ~~immediately preceding the 2nd~~ second division ~~dividing:~~ or

28 (2) The division of the tract or parcel is otherwise exempt under subsection D
29 below.

30 B. The dividing of a tract or parcel of land and the lot or lots so made, which
31 dividing or lots when made are not subject to the Ordinance, do not become
32 subject to the Ordinance by the subsequent dividing of that tract or parcel of land
33 or any portion of that tract or parcel of land. The municipal reviewing authority
34 shall consider the existence of the previously created lot or lots in reviewing a
35 proposed subdivision created by a subsequent dividing.

36 C. ~~A lot-Lots~~ of forty (40) or more shall not be counted as lots when the lot is
37 located entirely outside of the Shoreland Performance Overlay District.

38 D. Exceptions.

39 (1) A division accomplished by devise does not create a lot or lots for the
40 purposes of this definition, unless the intent of the transferor is to avoid the
41 objectives of the Ordinance.

1 (2) A division accomplished by condemnation does not create a lot or lots for the
2 purposes of this definition, unless the intent of the transferor is to avoid the
3 objectives of the Ordinance.

4 (3) A division accomplished by order of court does not create a lot or lots for the
5 purposes of this definition, unless the intent of the transferor is to avoid the
6 objectives of the Ordinance.

7 (4) A division accomplished by gift to a person related to the donor of an interest
8 in property held by the donor for a continuous period of five (5) years prior to
9 the division by gift does not create a lot or lots for the purposes of this
10 definition, unless the intent of the transferor is to avoid the objectives of the
11 Ordinance. If the real estate exempt under this definition is transferred within
12 five (5) years to another person not related to the donor of the exempt real
13 estate as provided in this paragraph, then the previously exempt division
14 creates a lot or lots for the purposes of the Ordinance. "Person related to the
15 donor" means a spouse, parent, grandparent, brother, sister, child or
16 grandchild related by blood, marriage or adoption. A gift under this definition
17 can not be given for consideration that is more than one-half (1/2) the assessed
18 value of the real estate.

19 (5) A division accomplished by a gift to a municipality if that municipality
20 accepts the gift does not create a lot or lots for the purposes of this definition,
21 unless the intent of the transferor is to avoid the objectives of the Ordinance.

22 (6) A division accomplished by the transfer of any interest in land to the owners
23 of land abutting that land does not create a separate lot does not create a lot or
24 lots for the purposes of this definition, unless the intent of the transferor is to
25 avoid the objectives of the Ordinance. If the real estate exempt under this
26 paragraph is transferred within five (5) years to another person without all of
27 the merged land, then the previously exempt division creates a lot or lots for
28 the purposes of the Ordinance.

29 (7) The grant of a bona fide security interest in an entire lot that has been
30 exempted from the definition of subdivision under subsection D above, or
31 subsequent transfer of that entire lot by the original holder of the security
32 interest or that person's successor in interest, does not create a lot for the
33 purposes of this definition, unless the intent of the transferor is to avoid the
34 objectives of the Ordinance.

35 E. The division of a tract or parcel of land into three (3) or more lots and upon each
36 of which lots permanent dwelling structures legally existed before September 23,
37 1971 is not a subdivision.

38 F. In determining the number of dwelling units in a structure, the provisions of the
39 Ordinance regarding the determination of the number of lots apply, including
40 exemptions from the definition of a subdivision of land.

41 G. Notwithstanding the provisions of the Ordinance, leased dwelling units are not
42 subject to subdivision review if the municipal reviewing authority has determined
43 that the units are otherwise subject to Site Plan Review under the Zoning

1 ~~Ordinance. For the purposes of this section, a tract or parcel of land is defined as~~
2 ~~all contiguous land in the same ownership, provided that lands located on~~
3 ~~opposite sides of a public or private road shall be considered each a separate tract~~
4 ~~or parcel of land unless such road was established by the owner of land on both~~
5 ~~sides thereof.~~

6
7 ~~“**Subdivision-Major Subdivision**” - a~~ subdivision containing more than five (5) lots,
8 or requiring ~~substantial~~ extension of municipal facilities, ~~or requiring~~ any new public
9 ~~road, street extension, or falling under the cluster provisions of the Zoning Ordinance, or~~
10 ~~multiplex housing as defined in the Zoning Ordinance or a manufactured housing park.~~

11 ~~“**Subdivision-Minor Subdivision**” - a~~ subdivision containing not more than five (5)
12 lots and is not otherwise defined ~~above~~ as a major subdivision.

13 **“Through road”** - a road with more than one means of ingress or egress. Both means of
14 ingress and egress must, at a minimum, meet the standards of an access road. ~~[Rev. eff.~~
15 ~~7/13/94]~~

16 **“Tract or parcel of land”**- tract or parcel of land means all contiguous land in the same
17 ownership, ~~except that lands located on opposite sides of a public or private road are~~
18 ~~considered each a separate tract or parcel of land unless the road was established by the~~
19 ~~owner of land on both sides of the road after September 22, 1971.~~

20 **“Town Engineer”**- that person ~~designated by the Town to provide engineering advice to~~
21 ~~the Planning Board in its subdivision and site plan review.~~

22 **“Traveled Way”** - that portion of a right-of-way which is regularly used for vehicular
23 traffic.

24 **Article II. Review Procedures**

25 **Sec. 16-2-1. General Procedures.** In all stages of the subdivision review process, the
26 burden of proof shall be upon the applicant proposing the subdivision.

27 **(a) Public Record.** ~~The Planning Board shall maintain a permanent record of all its~~
28 ~~meetings, proceedings and correspondence. The Planning Board shall specify in writing~~
29 ~~its decisions and findings of fact.~~

30 **(b) Public Notice.** ~~When notice to abutters is required, the Planner shall cause notice~~
31 ~~to be given by mail to the owners, as currently listed by the Town Tax Assessor, of all~~
32 ~~properties within 500’ of the proposed project property line boundary. If the project abuts~~
33 ~~an adjacent municipality, the Planner shall notify the adjacent municipality’s planning~~
34 ~~staff and request that all pertinent property owners be notified of the project proposal.~~
35 ~~Such notice shall include the date, time and location of the meeting and the location and~~
36 ~~general description of the proposed development.~~

37 ~~If a public hearing is scheduled, mailed notice shall be provided as described above. In~~
38 ~~addition, the Planner shall cause notice of the date, time and place of the hearing to be~~
39 ~~published at least two (2) times in a newspaper having general circulation in the Town of~~
40 ~~Cape Elizabeth. The date of the first publication must be at least seven (7) days before the~~
41 ~~public hearing.~~

1 (c) Review Escrow Account. In addition to the application fees set by the Town
2 Council, a Review Escrow Fee to defray the Town's costs for application review by the
3 Town Engineer and/or other independent consulting services shall be provided. The fee
4 shall be recommended by the Town Engineer or consultant and approved by the Town
5 Manager upon initial review of the application and paid to the Town by the applicant
6 prior to the next meeting with the Planning Board. The fee shall be deposited in a Review
7 Escrow Account designated for that application. If the costs of application review by the
8 Town Engineer and/or other consulting services exceed the amount of the Review
9 Escrow Account, the applicant shall pay an additional fee to the Town that shall be
10 recommended by the Town Engineer or consultant and approved by the Town Manager
11 based upon the status of the application. Any balance in the account remaining after a
12 final decision on the application by the Planning Board and satisfaction of any approval
13 conditions shall be returned to the applicant unless there is an appeal or other legal action
14 pending with respect to the Planning Board's approval. All interest from the Review
15 Escrow Account shall accrue to the account and shall be applied toward the Town's cost
16 in reviewing the application.

17
18 (d) Duration of Time. Unless otherwise specified, number of days shall be
19 calculated as calendar days.
20

21 **Sec. 16-2-2. Pre-Application Process.** Prior to submitting an application for subdivision
22 review, the applicant shall meet with the Planning Board at a workshop at least once to
23 discuss the proposal generally, acquaint the Planning Board with the nature of the
24 proposal and the location, topography and other attributes of its site, review potential
25 submission waivers and obtain preliminary classification of the proposal as either a minor
26 or major subdivision. The Planner shall arrange for public notice of the meeting in
27 accordance with Sec. 16-2-1(b) of this Ordinance.
28

29 **Sec. 16-2-3. Review and Approval of Minor Subdivisions**

30 **(a) Procedures.**

- 31 1. Formal Submission. The subdivision applicant or an agent duly authorized in writing,
32 shall submit to the Town Planner a subdivision application for consideration by the
33 Planning Board together with the fee therefore as prescribed by the Town Council,
34 and fourteen (14) complete copies of the proposed subdivision plans and materials.
35 All plans and materials shall be submitted at least eighteen (18) calendar days prior to
36 the Planning Board's next scheduled meeting. Prior to the first meeting with the
37 Planning Board, the applicant shall also establish a Review Escrow Account under
38 the terms in Sec. 16-2-1(c) of this Ordinance ~~(1)~~.
39
- 40 2. Preliminary Completeness. Within thirty- (30) days of the receipt of a final
41 subdivision application and accompanying materials, the Town Planner, in
42 consultation with the Planning Board Chairperson or Vice Chairperson, shall make a
43 preliminary determination as to completeness regarding whether the application is
44 complete or incomplete. If the application is preliminarily determined to be
45 incomplete, the Town Planner shall so notify the applicant in writing and shall list in

1 the written determination the materials that must be submitted in order to make the
2 application complete. If an applicant fails to submit a complete application within
3 four (4) months of the date of the ~~Town~~ Planner's preliminary written determination,
4 the application shall be deemed withdrawn. When the ~~Town~~ Planner makes the
5 preliminary determination that an application is complete, the application shall be
6 scheduled for consideration at the next available Planning Board meeting. Once
7 scheduled, the ~~Town~~ Planner shall promptly notify the applicant of the time and place
8 of such meeting. No action taken by the ~~Town~~ Planner, either alone or in consultation
9 with the Planning Board ~~Chair~~~~Chairperson or Vice Chairperson~~, with respect to
10 reviewing a subdivision application, shall result in an application being deemed
11 pending for the purposes of Title 1, M.R.S.A. Sec. 302. The ~~Town~~ Planner, either
12 alone or in consultation with the Planning Board ~~Chairperson or Vice Chairperson~~,
13 shall have no authority to review the substance of a subdivision application to
14 determine whether it complies with the subdivision review criteria.

15
16 3. Public Notice. ~~The Once scheduled, the Town Planner shall arrange for public notice~~
17 ~~of the meeting in accordance with Sec. 16-2-1 (b) of this Ordinance, also cause notice~~
18 ~~to be given by mail to the owners, as currently listed by the Town Tax Assessor, of all~~
19 ~~properties located within 1,000 feet of the proposed subdivision or of the 25~~
20 ~~properties located nearest to it, whichever number is less. If a proposed subdivision~~
21 ~~abuts an adjacent municipality, the Town Planner shall notify the adjacent~~
22 ~~municipality's planning staff and request that all pertinent property owners be~~
23 ~~notified of the minor subdivision proposal.~~

24 ~~seven (7)~~

25
26 43. Planning Board Completeness. At its first meeting for consideration of an application
27 for approval of a subdivision, ~~the Planning Board shall issue to the applicant a dated~~
28 ~~receipt for such application.~~
29 the Planning Board shall ~~then~~ determine whether the application is complete or
30 incomplete, ~~and shall notify the applicant of the Board's determination in writing~~
31 ~~within 30 days of the date that the receipt is issued. Within seven (7) days of the first~~
32 ~~regular meeting, the Planning Board shall provide to the applicant a dated letter~~
33 ~~acknowledging receipt of the application and the Planning Board's determination as~~
34 ~~to completeness.~~ If the application is determined to be incomplete, the Planning
35 Board shall list in its written determination the materials that must be submitted in
36 order to make the application complete. ~~When the application is determined to be~~
37 ~~complete, the Planning Board shall notify the applicant and begin full evaluation of~~
38 ~~the proposed subdivision.~~ If an applicant fails to submit a complete application within
39 ~~four (4) months of the Planning Board letter issued receipt or within four (4) months~~
40 ~~of the written determination of the Town Planner, the application shall be deemed~~
41 ~~withdrawn, unless said time limitation is otherwise extended by the Planning Board~~
42 ~~for good cause. When the application is deemed complete, the Planning Board shall~~
43 ~~begin review of the proposed subdivision.~~

44 54. Site Walk. ~~One or more~~ A site walk ~~by the Planning Board~~ may be scheduled by the
45 Planning Board. ~~The applicant shall provide temporary markers of key subdivision~~
46 ~~elements, such as but not limited to road centerlines and wetland boundaries, on the~~

1 site prior to the site walk at the request of the Planning Board. ~~once the dated receipt~~
2 ~~for an application is issued. Additional site walks may be scheduled, if deemed~~
3 ~~necessary by the Board.~~

4 ~~5. Minor Subdivision Classification. At its first meeting for application consideration,~~
5 ~~the Planning Board shall finalize classification of the proposed subdivision as either a~~
6 ~~minor or major subdivision. The Board at this meeting may require a minor~~
7 ~~subdivision to comply with some or all of the requirements specified for major~~
8 ~~subdivisions where the Board finds it necessary to determine compliance with the~~
9 ~~standards set forth in this Chapter.~~

10 6. Public Hearing. The Planning Board, ~~shall at its discretion, may~~ hold a public hearing
11 on a minor subdivision application. ~~If the Board determines to hold a hearing, it shall~~
12 ~~hold the hearing~~ within thirty (30) days of the date that the application is determined
13 to be complete. Public notice shall be provided in accordance with Section 16-2-1(b)
14 16-2-4(a)-(7) of this OrdinanceChapter.

15
16 The Planning Board shall conduct the hearing as to assure full, but not repetitive,
17 public participation. The applicant shall be prepared to respond fully to questioning
18 by the public and the Planning Board. The Planning Board may, upon its own motion,
19 extend the hearing once for a period not exceeding thirty (30) days and to a date that
20 shall be announced.

21 7. Planning Board Decision. The Planning Board shall approve, or approve with
22 conditions, or disapprove the Final Subdivision Plan: (i) within sixty (60) days from
23 the date of the date that the application is determined to be complete, or of (ii) within
24 such other time that may be mutually agreed upon by both the Planning Board and the
25 applicant. ~~The Planning Board shall specify in writing its decision and findings of fact~~
26 ~~regarding the decision.~~

27 ~~8. If the Board determines that security for performance is required for the completion~~
28 ~~of any proposed site improvements, the procedures and standards of Section 16-2-4~~
29 ~~(e)-(7) (A) shall apply and be met before final plan approval can be given.~~
30

31 **(b) Submission Requirements.** Minor Subdivision Plan submissions shall conform
32 to the standards and requirements contained in Appendix A of this Ordinance.

33
34 **Sec. 16-2-4. Review and Approval of Major Subdivision Plans.**

35
36 **(a) Preliminary Plan Procedures.**

37 1. Formal Submission. The subdivision applicant, or an agent duly authorized in writing,
38 shall submit to the ~~Town~~ Planner a subdivision application for consideration by the
39 Planning Board together with the fee therefore as prescribed by the Town Council,
40 and fourteen (14) complete copies of the proposed preliminary subdivision plans and
41 materials. All plans and materials shall be submitted at least eighteen (18) calendar
42 days prior to the Planning Board's next scheduled meeting. Prior to the first meeting
43 with the Planning Board, the applicant shall also establish a Review Escrow Account
44 under the terms in Sec. 16-2-1(c) of this Ordinance.
45

1 | 2. Preliminary Completeness. Within thirty- ~~(30)~~ days of the receipt of a preliminary
2 | subdivision application and accompanying materials, the ~~Town~~ Planner, in
3 | consultation with the Planning Board Chair~~person or Vice Chairperson~~, shall make a
4 | preliminary determination as to completeness, regarding whether the application is
5 | complete or incomplete. If the application is preliminarily determined to be
6 | incomplete, the ~~Town~~ Planner shall so notify the applicant in writing and shall list in
7 | the written determination the materials that must be submitted in order to make the
8 | application complete. If an applicant fails to submit a complete application within
9 | four (4) months of the date of the ~~Town~~ Planner's preliminary determination, the
10 | application shall be deemed withdrawn. ~~3.~~ — When the ~~Town~~ Planner makes the
11 | preliminary determination that an application is complete, the application shall be
12 | scheduled for consideration at the next available Planning Board Meeting. Once
13 | scheduled, the Planner shall promptly notify the applicant of the time and place of
14 | such meeting. No action taken by the ~~Town~~ Planner, either alone or in consultation
15 | with the Planning Board Chair~~person or Vice Chairperson~~, with respect to reviewing a
16 | subdivision application, shall result in an application being deemed pending for the
17 | purposes of Title 1, M.R.S.A. Section 302. The ~~Town~~ Planner, either alone or in
18 | consultation with the Planning Board Chair~~person or Vice Chairperson~~, shall have no
19 | authority to review the substance of a subdivision application to determine whether it
20 | complies with the subdivision review criteria.

21 |
22 | 3. Public Notice. The Planner shall arrange for public notice of the meeting in
23 | accordance with Sec. 16-2-1(b) of this Ordinance.

24 |
25 | 4. Planning Board Completeness. At its first meeting for consideration of an application
26 | for preliminary approval of a subdivision, the Planning Board ~~shall issue to the~~
27 | ~~applicant a dated receipt for such application. The Planning Board shall then~~
28 | ~~determine whether the application is complete or incomplete. Within seven (7) days~~
29 | ~~of the first regular meeting, the Planning Board shall provide to the applicant a dated~~
30 | ~~letter acknowledging receipt of the application and the Planning Board's~~
31 | ~~determination of completeness, and shall notify the applicant of the Planning Board's~~
32 | ~~determination in writing within 30 days of the date the receipt is issued.~~ If the
33 | application is determined to be incomplete, the Planning Board shall list in its written
34 | determination the materials that must be submitted in order to make the application
35 | complete. ~~(7)~~ If an applicant fails to submit a complete application within four (4)
36 | months of the ~~issued receipt~~ Planning Board letter or within four (4) months of the
37 | written determination of the ~~Town~~ Planner, the application shall be deemed
38 | withdrawn unless said time limitation is otherwise extended by the Planning Board
39 | for good cause. When the application is deemed ~~determined to be~~ complete, the
40 | Planning Board ~~shall notify the applicant and shall~~ begin review full evaluation of the
41 | proposed subdivision.

42 |
43 | 5. Site Walk. ~~A site walk by the Planning Board may be scheduled, once the Planning~~
44 | ~~Board determines the application to be complete. One or more~~ Additional site walks
45 | may be scheduled, ~~if deemed necessary,~~ by the Planning Board. The applicant shall
46 | provide temporary markers of key subdivision elements, such as but not limited to

1 road centerlines and wetland boundaries, on the site prior to the site walk at the
2 request of the Planning Board.

3
4
5 ~~6. At its first meeting for application consideration, the Planning Board shall finalize~~
6 ~~classification of the proposed subdivision as either a major or minor subdivision.~~

7
8 ~~67. Public Hearing. The Planning Board shall hold a public hearing on a major~~
9 ~~subdivisionsuch application wWithin thirty (30) days of the date its determination~~
10 ~~that thea preliminary subdivision application is determined to be complete. Public~~
11 ~~notice shall be provided in accordance with Sec. 16-2-1(b) of this Ordinance. It shall~~
12 ~~cause notice of the date, time, place and purpose of the hearing to be given the~~
13 ~~applicant and to be published at least twice in a newspaper of general circulation in~~
14 ~~the Town, the date of the first publication to be at least 7 days prior to the hearing~~
15 ~~date. It shall also cause notice to be given by mail to the owners, as currently listed by~~
16 ~~the Town Tax Assessor, of all properties located within 1,000 feet of the proposed~~
17 ~~subdivision, or of the 25 properties located nearest to it, whichever number is less;~~
18 ~~any failure of delivery of such mailed notices shall not invalidate the hearing for~~
19 ~~which given. If a proposed subdivision abuts an adjacent municipality, the Board~~
20 ~~shall notify the adjacent municipality's planning staff and request that all abutting~~
21 ~~property owners be notified of the public hearing.~~

22
23
24 The Planning Board shall ~~so~~ conduct the hearing as to assure full, but not repetitive,
25 public participation. The applicant shall be prepared to respond fully to questioning
26 by the public and the Planning Board. The Planning Board may, upon its own
27 motion, extend the hearing once for a period not exceeding thirty (30) days and to a
28 date thatwhich shall be announced. ~~The Board may adopt regulations governing the~~
29 ~~operation of said public hearings and it shall keep minutes thereof.~~

30 ~~78. Planning Board Decision. The Planning Board shall approve, or approve with~~
31 ~~conditions, or disapprove the Preliminary Plan: (i) within thirty (30) days after the~~
32 ~~date of the public hearing, or (ii) within such other time that may be mutually agreed~~
33 ~~upon by both the Planning Board and the applicant. The Planning Board shall specify~~
34 ~~in writing its findings of fact and the Board's decision. Terms and conditions imposed~~
35 ~~by the Board shall be those it deems advisable to satisfy the criteria listed in Sec. 16-~~
36 ~~1-1 (a) through (n) and the design standards set forth in Article III of these~~
37 ~~Regulations, and to protect and preserve the public's health, safety and general~~
38 ~~welfare. Such terms and conditions shall include the issuance of any permits or~~
39 ~~approval required for such subdivision from any federal, state or other local body or~~
40 ~~authority, and they may include changes in the proposed subdivision or additional~~
41 ~~materials corroborating matters already presented.~~ 9. Preliminary Plan approval shall
42 not constitute approval of the Final Plan, but rather shall be deemed an expression of
43 approval of the approach submitted on the Preliminary Plan as a guide to preparation
44 of the Final Plan.

45
46 **(b) Preliminary Plan Submission Requirements.**

1 Preliminary Plan submissions shall conform to the standards and requirements contained
2 in Appendix B of this Ordinance.

3 **(c) Final Plan Procedures-**

4 1. Formal Submission. Within six (6) months following the Planning Board's approval
5 or approval with conditions of an applicant's Preliminary Plan, the applicant shall file
6 with the ~~Town~~ Planner for Planning Board consideration, a Final Plan application for
7 the subdivision with fourteen (14) copies of the materials herein prescribed. If such
8 application is not filed within such period, the application shall be deemed withdrawn
9 and shall no longer be considered a pending subdivision application, unless said time
10 limitation is otherwise extended by the Planning Board for good cause. ~~Prior to the~~
11 ~~first meeting with the Planning Board, the applicant shall also establish a Review~~
12 ~~Escrow Fee Account under the terms in Sec. 16-2-4(a)(21).~~

13
14 ~~2. Prior to submission of the Final Plan application, the applicant shall have fulfilled the~~
15 ~~following requirements and submitted written evidence of requirement to the Board:~~

16 ~~(A) Written evidence of the issuance of all permits, licenses and approvals required for~~
17 ~~the subdivision from any federal, state or other local agency;~~

18
19 ~~(B) Written evidence of an adequate supply of domestic water, in the form of (i) approval~~
20 ~~by the Portland Water District, (ii) approval by the appropriate state agency of any~~
21 ~~proposed central water supply system, or (iii) approval by a registered Maine~~
22 ~~engineer if individual wells are to be used for building sites, in which latter case the~~
23 ~~board may also require reports by the appropriate state agency of the results of all~~
24 ~~water quality tests;~~

25
26 ~~(C) Written evidence of (i) the availability of public sewage service for some or all of the~~
27 ~~lots; or (ii) compliance with the clustered sewer system provisions of Chapter 15,~~
28 ~~reviewed by the Town Engineer, receipt of a letter from the Maine Department of~~
29 ~~Human Services, and written approval of the local plumbing inspector; or (iii)~~
30 ~~municipal approval of the proposed sewage disposal systems, to be designed and~~
31 ~~installed in compliance with the Town Sewer Ordinance, and which shall require the~~
32 ~~review and approval by the Town Engineer and the building inspector of the subsoils~~
33 ~~and of said sewage disposal arrangement;~~

34
35 ~~(D) Written evidence of (i) the offer and conditional municipal approval of all roads,~~
36 ~~sewer lines, drainage easements, proposed public open space, recreation land, and all~~
37 ~~other facilities proposed to be dedicated to the Town; or (ii) satisfactory agreements,~~
38 ~~restrictive covenants, deed restrictions, condominium declaration or other documents~~
39 ~~showing the manner in which private roads, sewer lines and systems, drainage ways,~~
40 ~~open space, recreation land, and other such common areas and facilities are to be~~
41 ~~maintained. Written agreements of a dedication to a third party other than the Town~~
42 ~~must also be submitted and deemed satisfactory by the Board.~~

43
44 2. Final Subdivision Plan Preliminary Completeness. Within thirty (30) days of the
45 receipt of a final subdivision application and accompanying materials. ~~When the~~
46 ~~Town~~ the Planner makes the preliminary determination, in consultation with the

1 Planning Board Chair ~~person or Vice Chairperson~~, shall make a preliminary
2 determination of completeness. If the application is preliminarily determined to be
3 incomplete, the Planner shall so notify the applicant in writing and shall in the written
4 determination the materials that must be submitted in order to make the application
5 complete. If an applicant fails to submit a complete application within four (4) month
6 of the date of the Planner's preliminary written determination, the application shall be
7 deemed withdrawn.- When the Planner makes the preliminary determination that an
8 application is complete, the application shall be scheduled for consideration at the
9 next available Planning Board meeting. Once scheduled, the Planner shall promptly
10 notify the applicant of the time and place of such meeting. No action taken by the
11 Planner, either alone or in consultation with the Planning Board Chair, with respect to
12 reviewing a subdivision application, shall result in an application being deemed
13 pending for the purposes of Title 1 M.R.S.A. Sec. 302. The Planner, either alone or in
14 consultation with the Planning Board Chair, shall have no authority to review the
15 substance of a subdivision application to determine whether it complies with the
16 subdivision review criteria.and in following with the procedure set forth in Section
17 16-2-4 (a) (2) of this Ordinance, that all materials required to constitute a complete
18 application have been submitted by an applicant, the Town Planner shall schedule
19 consideration of the application for its next available Planning Board meeting. The
20 applicant shall also be promptly notified of the time and place for such meeting.

21
22 3. Public Notice. Once a Planning Board meeting is scheduled, the Planner shall also
23 cause notice to be given per Sec. 16-2-1(b) of this Ordinance.

24
25 4. Planning Board Final Subdivision Plan Completeness. At its first meeting for
26 consideration of an application for final approval of a subdivision, the Planning Board
27 shall issue to the applicant a dated receipt for such application. ~~The Planning Board~~
28 ~~shall then~~ determine whether the application is complete or incomplete, ~~and shall~~
29 ~~notify the applicant of the Board's determination in writing 35 days of the date that~~
30 ~~the receipt is issued~~. Within seven (7) days of the first regular meeting, the Planning
31 Board shall provide to the applicant a dated letter acknowledging receipt of the
32 application and the Planning Board's determination of completeness. If the
33 application is determined to be incomplete, the Planning Board shall list in its written
34 determination the materials that must be submitted in order to make the application
35 complete. ~~Any application not determined to be complete~~ If an applicant fails to
36 submit a complete application within four (4) months ~~of the issued receipt date~~
37 Planning Board letter or within four (4) months of the written determination of the
38 Planner, the application shall be deemed withdrawn and shall no longer be considered
39 a pending subdivision application, unless said time limitations is otherwise extended
40 by the Planning Board for good cause. When the application is ~~determined to be~~
41 deemed complete, the Planning Board shall ~~notify the applicant and~~ begin review full
42 evaluation of the proposed subdivision.

43
44 5. Site walk. One or more site walks may be scheduled by the Planning Board. The
45 applicant shall provide temporary markers of key subdivision elements, such as but

1 not limited to road centerlines and wetland boundaries, on the site prior to the site
2 walk at the request of the Planning Board.

3
4 ~~65. Public Hearing.~~ The Planning Board may schedule a public hearing on the ~~f~~Final
5 ~~Subdivision p~~Plan if it considers any changes in the plan sufficient to warrant further
6 public comment. Public notice shall be given in accordance with Section 16-2-~~1 (b)~~4
7 ~~(a) (6)~~ of this Ordinance.

8
9 If a public hearing is held, the Planning Board shall conduct the hearing as to assure
10 full, but not repetitive, public participation. The applicant shall be prepared to
11 respond fully to questioning by the public and the Planning Board. The Planning
12 Board may, upon its own motion, extend the hearing once for a period not exceeding
13 thirty (30) days and to a date which shall be announced.

14
15 ~~6. The Planning Board shall set the amount, terms and conditions of a performance~~
16 ~~guarantee to secure completion of all required public improvements. The applicant~~
17 ~~shall provide cost estimates of the required improvements, which shall be reviewed~~
18 ~~and modified if necessary by the Town Engineer.~~

19
20 ~~Prior to a Planning Board Decision, the applicant shall:~~

21 ~~A. Submit to the Planning Board a performance guarantee in the form of a irrevocable~~
22 ~~letter of credit or escrow account in favor of the Town in an amount based on a~~
23 ~~detailed estimate prepared by the applicant and reviewed by the Town Engineer~~
24 ~~accompanied by a schedule of work to be appended to the performance guarantee.~~
25 ~~The amount shall be set by the Board as sufficient to cover the cost of whichever~~
26 ~~amount is greater of the following: (i) proper completion of all roads, sewer, water,~~
27 ~~drainage, open space and other required improvements, or (ii) reasonable restoration~~
28 ~~of the subdivision tract. The reasonable costs that may be incurred in enforcing the~~
29 ~~performance guarantee granted to the Town shall also be included in the amount of~~
30 ~~the performance guarantee including possible legal fees. Such performance guarantee~~
31 ~~shall be satisfactory to the Town Manager and to the Town Attorney as to the issuer,~~
32 ~~form sufficiency, surety and manner of execution, provided that all performance~~
33 ~~guarantees shall contain a provision requiring the issuer or escrow agent to notify the~~
34 ~~Town Manager in writing of the scheduled expiration date at least thirty (30) days and~~
35 ~~not more than ninety (90) days in advance of its scheduled expiration date. The Board~~
36 ~~shall determine the~~
37 ~~period of not less than one (1) year nor exceeding three (3) years, which shall~~
38 ~~be stated in the performance guarantee within which required improvements~~
39 ~~shall be completed. Extensions of the performance guarantee may be granted~~
40 ~~by the Town Manager for up to three (3) years from the initial expiration date~~
41 ~~at the request of the applicant for good cause; and~~

42
43 ~~B. Present to the Board any survey map required for the subdivision for approval as~~
44 ~~conforming to the final plans to be noted thereon by signatures of a majority of the~~
45 ~~board members.~~

1 | 7. Planning Board Decision. The Planning Board shall approve, or approve with
2 | conditions or disapprove the Final Subdivision Plan: (i) within ~~10~~ thirty (30) days of
3 | the date of the public hearing; (ii) within sixty (60) days of the date that the
4 | application was determined to be complete if no public hearing is held; or (iii) within
5 | such other time that may be mutually agreed upon by both the Planning Board and the
6 | applicant.

7 |
8 | **(d) Final Plan Submission Requirements.** Final Subdivision Plan submissions shall
9 | conform to the standards and requirements contained in Appendix B of this Ordinance.

10 | ~~(e) — Phasing . The Planning Board after preliminary plan approval may permit a~~
11 | ~~subdivision to be divided into two or more phases for purposes of final approval. and to~~
12 | ~~assure compliance with this Chapter. The Board shall sign and the applicant shall record~~
13 | ~~a subdivision plat which depicts all phases of the subdivision and which prominently~~
14 | ~~notes that no lots will be sold, nor building permits issued, nor site work commenced in~~
15 | ~~phases for which a performance guarantee has not been approved in accordance with Sec.~~
16 | ~~16-2-4 (e)(7)(A). The amount, terms and conditions of any performance guarantee shall~~
17 | ~~correspond with the phase or phases scheduled to be constructed and shall otherwise~~
18 | ~~satisfy the procedures and standards of Section 16-2-4 (e) (7) (A). All phases of a~~
19 | ~~subdivision must receive final approval, or shall be identified as an area of possible future~~
20 | ~~development for which Planning Board approval has not been granted.~~

21 | ~~(f) — Action Upon Approval. Upon completion of the requirements set forth in Sec.~~
22 | ~~16-2-4, (d) and (e) above, and notation to that effect upon the final plans, Any alteration~~
23 | ~~in a final plan after its approval by the Planning Board has been endorsed thereon shall~~
24 | ~~render such final plan null and void, unless such alteration has received the prior approval~~
25 | ~~of the Planning Board. within that time limit stating that the plan has been recorded and~~
26 | ~~giving the book and page number and two copies of the final recorded plan.~~

27 |
28 | **Sec. 16-2-5. Amendments to Previously Approved Subdivision Plans**

29 | **(a) Scope-** Any change in an approved final subdivision plan including but not limited to
30 | lot lines, road layout, and location of structures and improvements must be reviewed
31 | and approved by the Planning Board. De minimis changes to an approved
32 | subdivision plan may be placed on the Planning Board Consent Agenda at the
33 | discretion of the ~~Town~~ Planner.

34 | **(b) De minimis Changes-** De minimis changes shall not include (1) an increase in the
35 | number of lots or units, (2) a change to a public or private right-of way or easement,
36 | (3) a decrease in proposed buffering or landscaping, or (4) any issue involving a
37 | condition placed on the Subdivision approval. Prior to placement on the Consent
38 | Agenda, the applicant shall meet with the ~~Town~~-Planner to review the proposed
39 | changes and shall provide eight (8) copies of the revised recording plat to the ~~Town~~
40 | Planner at least eighteen (18) days prior to the next regular Planning Board meeting.
41 | The decision of the ~~Town~~ Planner to not place an item on the Consent Agenda may be
42 | appealed to the Planning Board upon submission of fourteen (14) copies of the
43 | proposed change to the ~~Town~~ Planner eighteen (18) days prior to the next Planning
44 | Board meeting.

1 | **(c) Procedure.** A public hearing may be held concerning a subdivision amendment as
2 | prescribed in Sec. 16-2-1(b) of this Ordinance. The Planning Board may request the
3 | submission of information included in Appendix A or B and shall review the
4 | subdivision amendment for compliance with the standards in Sec. ~~16-3-1~~ of this
5 | Ordinance. All amended plans must make specific reference to the original plan and
6 | its recording information. The Planning Board Decision shall be to approve, approve
7 | with conditions or deny the subdivision amendment, ~~must be signed by a majority of~~
8 | ~~the Planning Board and recorded in the Registry of Deeds within ninety (90) days~~
9 | ~~following the Planning Board Decision. Any amended plan not so filed or recorded~~
10 | ~~within ninety (90) days following the date of the Planning Board decision shall~~
11 | ~~become null and void. The applicant may request, prior to the expiration date, that the~~
12 | ~~Planning Board grant an extension due to the particular circumstances of the~~
13 | ~~applicant, which extension shall not exceed an additional period of ninety (90) days.~~
14 | ~~The applicant shall provide the Town Planner with a receipt from the Registry of~~
15 | ~~Deeds within that time limit stating that the plan has been recorded and giving the~~
16 | ~~book and page numbers and two copies of the final recorded plan.~~

17 |
18 | **(d) Subdivision vacation.** Once a subdivision has been recorded, a subdivision where no
19 | lots have been sold or the entire subdivision is owned by one entity and no alteration
20 | to commence the subdivision has occurred on the site, may be vacated in its entirety
21 | by a vote of the Town Council at the request of the subdivision owner. Anything less
22 | than a complete vacation of the subdivision must be submitted to the Planning Board
23 | as an amendment. Approval by the Town Council to vacate the subdivision must be
24 | recorded in the Cumberland County Registry of Deeds.

25 |
26 | **Sec. 16-2-6. Post Approval Requirements.**

27 | **(a) Satisfaction of Planning Board Conditions of Approval.** Following the Planning
28 | Board Decision, the subdivision plans and materials shall be revised by the applicant
29 | to comply with any conditions placed on the approval by the Planning Board. Two (2)
30 | sets of revised plans shall be submitted to the Planner. The Planner, and other town
31 | staff as necessary, shall review all plans for compliance with the Planning Board
32 | conditions of approval. The Planner shall determine whether the plans have been
33 | revised to comply with the Planning Board approval. If the applicant fails to obtain
34 | confirmation from the Planner that the plans are in compliance with the conditions
35 | placed on the approval, the applicant may submit the revised subdivision plans to the
36 | Planning Board in accordance with Sec. 16-2-3(a)(1) of this Ordinance for minor
37 | subdivisions or Sec. 16-2-4(c)(1) of this Ordinance for major subdivisions.

38 | **(b) Plan Recording.** Once the plans are determined to be in compliance with the
39 | Planning Board approval, the recording plan they shall be properly signed by a majority
40 | of the Planning Board, and shall be recorded by the subdivider applicant in the
41 | Cumberland County Registry of Deeds. If the subdivision approval includes phasing of
42 | the subdivision, the recording plan shall depict all phases of the subdivision. Any final
43 | plans not so recorded within ninety (90) days following the date of Planning Board
44 | Decision shall become null and void. The applicant may request, prior to the expiration
45 | date, that the Planning Board grant an extension due to particular circumstances of the
46 | applicant which extension shall not exceed an additional period of ninety (90) days.

1 Once recorded, the subdivider applicant shall provide the Town Planner with three (3)
2 paper copies of the subdivision plat with the Planning Board signatures and the book and
3 page recording information a receipt from the Registry of Deeds.

4 **(e) Final Plan Approval & Filing.**

- 5 ~~1. Upon completion of the requirements above, the Final Plan shall be signed by a~~
6 ~~majority of the Planning Board and shall be recorded by the applicant in the~~
7 ~~Cumberland County Registry of Deeds. There shall be no sale of lots, issuance of~~
8 ~~building permits, nor site work, however, until the required performance guarantee~~
9 ~~has been approved in accordance with Sec. 16-2-4 (e)(7)(A).~~
- 10 ~~2. An approval of any subdivision plan not filed for recording within 90 days after the~~
11 ~~Planning Board Decision shall become null and void. The applicant may request,~~
12 ~~prior to the expiration date, that the Planning Board grant an extension due to the~~
13 ~~particular circumstances of the applicant, which extension shall not exceed an~~
14 ~~additional period of ninety (90) days. A note referencing this time provision shall be~~
15 ~~placed upon the Final Plan, provided the failure to reverence this provision shall in no~~
16 ~~way limit the effect of this provision. The developer shall provide the Code~~
17 ~~Enforcement Administrator with the plan book number and page number upon~~
18 ~~recording of the subdivision plan and two copies of the final recorded plans.~~

19

20 **(c) Performance Guarantee.** There shall be no sale of lots, nor building permits issued,
21 nor site work commenced until a Performance Guarantee has been approved by and
22 posted with the Town of Cape Elizabeth Town Manager. Submit to the Planning
23 Board a

- 24
- 25 1. Form. The Performance Guarantee shall be in the form of an irrevocable
26 letter of credit or escrow account in favor of the Town. Such Performance
27 Guarantee shall be satisfactory to the Town Manager and to the Town
28 Attorney as to the issuer, substantive form sufficiency, surety and manner of
29 execution, provided that all All performance guarantees shall contain
30 a provision requiring the issuer ~~to notify the town or escrow agent~~ to notify
31 the Town Manager in writing of the scheduled expiration date at least thirty
32 (30) days and not more than ninety (90) days in advance of its scheduled
33 expiration date. Extensions of the Performance Guarantee may be granted
34 by the Town Manager for up to three (3) years from the initial expiration date
35 at the request of the applicant for good cause.
- 36
- 37 2. Amount. The Performance Guarantee in an amount shall be based on a
38 detailed estimate prepared by the applicant, broken down by unit cost and
39 quantity, and reviewed by the Town Engineer. Costs included in the estimate
40 shall include, but not be limited to, accompanied by a schedule of work to be
41 appended to the performance guarantee. The amount shall be set by the Board
42 as sufficient to cover the cost of whichever amount is greater of the following:
43 (i) proper completion of all roads, sewer, water, drainage, open space,
44 landscaping, lighting and other required improvements shown on the approved
45 plans, or (ii) reasonable restoration of the subdivision tract. The reasonable
46 costs that may be incurred in enforcing the performance guarantee granted to

1 the Town shall also be included in the amount of the performance guarantee
2 including possible legal fees. The cost estimate shall also include a
3 contingency amount equal to ten (10) percent of the Performance Guarantee
4 estimate. The Board shall determine the
5 period of not less than one (1) year nor exceeding three (3) years, which shall
6 be stated in the performance guarantee within which required improvements
7 shall be completed.; and
8

9 3. Phasing. When the Planning Board has approved phasing of a subdivision, a
10 Performance Guarantee may be posted for one (1) or more phases. The
11 amount, terms and conditions of the Performance Guarantee shall correspond
12 with the phase or phases scheduled to be constructed. Construction activity
13 shall only be located and permitted in phases for which a Performance
14 Guarantee has been posted.
15

16 4. Reductions and Release. All requests for reduction or release of the
17 Performance Guarantee shall be submitted in writing to the Town Manager.
18 Reduction requests should only be submitted after significant construction has
19 been accomplished. Prior to approving a reduction or release of a Performance
20 Guarantee, the Town Manager shall request a report from the Town Engineer
21 confirming the quality and value of the construction completed. Any
22 reduction or release shall preserve the Town's ability to require or complete
23 construction that is consistent with the approved plans and the Town's
24 construction standards and/or restore and stabilize the site if construction will
25 not be continued. There shall be no final release of any Performance
26 Guarantee until the as-built plans-record drawings have been received and
27 approved by the Town Engineer.
28

29 **(d) Inspection Fee.** In addition to the Performance Guarantee, the applicant shall pay an
30 inspection fee. ~~When the Performance Guarantee equals five hundred thousand~~
31 ~~dollars (\$500,000) or less, the inspection fee amount shall be in the amount of five~~
32 percent (5%) of the ~~amount~~ cost of the total performance guarantee. ~~When the~~
33 ~~Performance Guarantee exceeds five hundred thousand dollars (\$500,000), the~~
34 ~~inspection fee amount shall be two and one-half percent (2.5%) of the cost of the total~~
35 ~~Performance Guarantee. The fee shall be payable by certified check to the Town of~~
36 Cape Elizabeth. The inspection fee shall be held by the Town to defray the Town's
37 cost for inspection by the Town Engineer ~~and, part-time Town staff, and the~~
38 ~~construction monitor.~~ Any funds not disbursed for this purpose shall be returned to
39 the applicant upon release of the Performance Guarantee. If the costs for inspection
40 exceed the amount of the ~~i~~nspection ~~f~~ee, the applicant shall pay an additional fee to
41 the Town, which shall be recommended by the Town Engineer and approved by the
42 Town Manager based on the status of the development.

43 **Sec. 16-2-7. Construction Administration**

44 **(a) Commencement of Construction.** At least ten (10) days prior to commencing
45 construction of required improvements, the ~~subdivider~~ applicant shall request a pre-
46 construction meeting with the Town Manager. At the meeting, the subdivider shall

1 submit plans ~~for construction of the subdivision and to the Town Engineer and he~~
2 ~~applicant shall~~ notify the Town Manager ~~in writing of the time when he proposes to~~
3 ~~commence~~ construction of such improvements ~~will commence so that~~ The subdivider
4 is also responsible for communicating ongoing progress of construction so that the
5 Town can cause inspections and so that requirements shall be met during construction
6 and to assure satisfactory completion of all improvements and utilities required by the
7 Planning Board. [Revised eff. 11/11/83; Revised eff. 6/13/90]
8

9 **(b) Notice of Inspection.** To assure proper inspection of roads and other required
10 improvements, the Town Engineer should be given not less than twenty-four (24)-
11 hour notice by the subdivider applicant for inspections required at the following
12 construction stages: (1) before backfilling of any surface water, sanitary sewer,
13 domestic water or other underground lines or improvements, (2) at completion of
14 road subgrades and after installation of gravel surface, (3) at the commencement of
15 paving, loaming, or other final surface preparation, and (4) upon final completion.
16

17 **(c) Inspection of Required Improvements.** All required subdivision improvements for
18 which a Pperformance Gguarantee ~~shall have been are~~ required shall be constructed
19 under the observation of a qualified construction monitor. The qualifications of the
20 construction monitor shall be subject to the review and approval of the Town.
21 ~~employed by the Town during the construction phase of the project.~~ Construction
22 monitoring costs shall be borne by the subdivider applicant and shall be included in
23 ~~the Inspection Fee in subsection (a) below.~~ The construction monitor shall be on the
24 site during all periods of time when significant construction is taking place.
25 Significant construction shall include (1) embankments, (2) bedding and backfilling
26 of all underground utilities including water lines, unless the installation is supervised
27 by the utility company. (3) installation of storm drainage and associated structures,
28 (4) installation of sanitary sewers and associated structures, (5) roadway subbase
29 material, (6) roadway base material, (7) paving, (8) compaction testing, and (9) sewer
30 and manhole testing. The duties of the construction monitor shall also include (1)
31 review knowledge of product reports and material submittals, (2) maintenance of a
32 diary of construction progress, and (3) implementation of remedial measures.

33 **(de) Authority of Town Engineer.** The Town Engineer shall have access to the site
34 at all times to review the progress of the work and shall have the authority to review
35 the field logs maintained by the construction monitor. Any deficiencies noted by the
36 Town Engineer shall be brought to the attention of the construction monitor who shall
37 see that remedial measures are taken.
38

39 If the Town Engineer shall finds upon inspection of required improvements, including
40 an inspection to be done by the Town Engineer before expiration of the
41 Pperformance Gguarantee, that any of such improvements are not ~~being~~ constructed
42 in accordance with plans and specifications filed by the subdivider applicant, or that in
43 the Town Engineer's his judgment the applicant will be unable to complete the
44 required improvement within the period specified in the Pperformance Gguarantee,
45 the Town Engineerhe shall then so notify the subdivider applicant and the Town
46 Manager, who shall take all necessary steps to preserve the rights of the Town under

1 | the ~~P~~performance ~~G~~guarantee, including authorization to the Town Engineer to stop
2 | the construction of said improvements.

3 |
4 | ~~(ed)~~ **Field ChangesModification**. If at any time before or during the construction of
5 | the required improvements the ~~subdivider~~applicant demonstrates to the satisfaction of
6 | the Town Engineer that unforeseen conditions make it desirable to modify the design
7 | of such improvements, ~~the Town~~sueh Eengineer may, in consultation with the Public
8 | Works Director and Planner~~upon approval by the Planning Board~~, authorize
9 | modifications provided that they are within the spirit and intent of the Planning Board
10 | approval and do not constitute waiver or substantial alteration of the function of any
11 | improvements required by the Planning Board. The Town Engineer shall issue any
12 | authorization under this section in writing, and ~~he~~shall transmit a copy of such
13 | authorization to the Planner and Planning Board~~at its next regular meeting~~.

14 |
15 | ~~(fe)~~ **Record drawingsCompletion and Acceptance**. Upon completion of construction,
16 | the ~~subdivider~~applicant shall present to the Town one (1)a set of reproducible mylar, one
17 | (1) hard copy, and one (1) electronic file of record drawings indicating facilities as
18 | constructed. The record drawings shall be based on the field logs of the construction
19 | monitor and of a quality acceptable to the Town,~~and bear the professional seal of a~~
20 | ~~design engineer or landscape architect~~.

21 | ~~As built drawings consisting of two paper copies and one reproducible copy shall be~~
22 | ~~submitted to the Public Works Director prior to public acceptance of public~~
23 | ~~improvements by the Town Council.~~ The as-built record drawings shall include an
24 | engineer's seal, distances, angles and bearings for complete and accurate determinations
25 | of locations on the ground, right-of-way monuments and as set, as-built profiles of the
26 | centerlines of traveled ways, ledge elevations encountered during construction and
27 | information on the locations, size, materials and elevations of storm drains, sanitary
28 | sewers and other underground utility lines, including but not limited to water, electric,
29 | telephone, natural gas, cable television. ~~Upon approval of such as-built plans by the~~
30 | ~~Town Engineer, the applicant may initiate municipal acceptance of any improvements to~~
31 | ~~be dedicated or transferred to the Town, and may initiate any other permanent~~
32 | ~~arrangements for the management, maintenance and operation of any other required~~
33 | ~~improvements. A set of the final plans shall be submitted to the Town Manager.~~

34 | **(g) Completion and Acceptance**. Upon completion of the subdivision infrastructure, the
35 | subdivider may request that the Town Council accept proposed public improvements.
36 | The request shall include confirmation from the Town Manager that the improvements
37 | have been constructed consistent with the approved plans and town construction
38 | standards and that any applicable deeds have been submitted in a form acceptable to the
39 | Town Attorney and signed by the subdivider. The applicant shall be required to maintain
40 | all improvements and to provide for snow removal on roads and sidewalks, until their
41 | acceptance by the Town or the assumption of those responsibilities under such other
42 | approved arrangements. ~~(Revised eff 12/10/03)~~

43 |
44 | **Article III. Standards**

1 **Sec. 16-3-1. General Subdivision Review Standards, of Subdivision Design A**
2 subdivision shall meet all of the following standards of review, as determined by the
3 Planning Board.

4 **(a) Pollution**

5 The proposed subdivision will not result in undue water pollution. Factors to consider
6 include:

- 7 1. The elevation of the land above sea level and its relation to the floodplains.
- 8 2. The nature of soils and subsoils and their ability to adequately support waste
9 disposal.
- 10 3. The slope of the land and its effect on effluents.
- 11 4. The availability of streams for disposal of effluents.
- 12 5. The applicable state and local health and water resource rules and regulations.

13 **(b) Sufficient Potable Water**

14 The proposed subdivision has sufficient water available for the reasonably
15 foreseeable needs of the subdivision. If a public water supply will be used, the
16 proposed subdivision will not cause an unreasonable burden on the existing public
17 water supply.

18 **(c) Erosion**

19 The proposed subdivision will not cause unreasonable soil erosion or a reduction in
20 the land's capacity to hold water so that a dangerous or unhealthy condition results.

21 **(d) Traffic**

22 1. Road congestion and safety. The proposed subdivision will not cause unreasonable
23 highway or public road congestion or unsafe conditions with respect to the use of
24 the highways or public roads existing or proposed, and if the proposed
25 subdivision requires driveways or entrances onto a state or state aid highway
26 located outside the urban compact area of an urban compact municipality as
27 defined by Title 23, M.R.S.A. Section 745, the Department of Transportation has
28 provided documentation indicating that the driveways or entrances conform to
29 Title 23, M.R.S.A Section 704 and any rules adopted under that section.

30 ~~(a)~~ 2. Comprehensive Plan. The proposed subdivision road(s) shall conform
31 to the Comprehensive Plan as adopted in whole or in part by the Town Council.

32
33 3. Connectivity. The Planning Board may require provision for the projection of
34 roads or for access to adjoining property, whether subdivided or not. The Planning
35 Board shall require that access from the subdivision to previously existing or
36 proposed public ways include two means of such vehicular access, as described in
37 Sec. 16-3-2(5) of this Ordinance.

38
39 ~~(b)~~ 4. Safety. All roads within a subdivision and roads providing access to a
40 subdivision shall be designed so that they will provide safe vehicular and

1 pedestrian travel and traffic patterns. ~~Access roads shall not be placed within 125~~
2 ~~feet of an intersection.~~

3
4 5. Through traffic. The Planning Board may require that local roads be laid out so
5 that their use by through traffic will be discouraged. ~~_____ The board shall~~
6 ~~require that roads be designed so as to provide safe, convenient and attractive~~
7 ~~access from the subdivision to previously existing or proposed public ways, which~~
8 ~~may include two or more means of such vehicular access; it may require that such~~
9 ~~roads be constructed in their entirety and be finally accepted prior to the issuance~~
10 ~~of any building permits for construction of dwellings thereon; and it may withhold~~
11 ~~approval of preliminary or final subdivision plans until such access is provided for~~
12 ~~by the applicant over his own and/or other abutting property.~~

13
14 6. Topography. Roads in the proposed subdivision shall be laid out in an attractive
15 manner, in order to enhance the livability and amenity of the subdivision. Insofar
16 as possible, roads shall conform to existing topography, and high cuts and fills
17 shall be avoided.

18
19 7. Block Length. Block lengths shall not exceed one thousand (1,000) feet except
20 where a greater length suits the topography or character of the subdivision and
21 does not result in an awkward road pattern or detrimental effect to adjacent
22 property.

23
24 8. Lot Access. Each property shall be provided with vehicular access to each lot by
25 an abutting public or private road. A private road shall be protected by a
26 permanent easement which shall conform to the Road Classification Standards
27 Table and which shall be shown on the plan.

28
29 9. Sidewalks/pedestrian connections. The Planning Board may require sidewalks
30 and/or curbing on either or both sides of any road, where they are or may be
31 necessary for maintenance and/or public safety, as determined by the Planning
32 Board.

33
34 _____ Provision of pedestrian easements or other types of pedestrian accessways not less
35 than ten (10) feet wide may be recommended to the applicant, where a pedestrian
36 accessway would add to the Town's Greenbelt System or where the Planning
37 Board deems it important for pedestrian enjoyment or to provide access to but not
38 limited to schools, playgrounds, shopping centers, recreation areas, open space,
39 trails, shore frontage, and other facilities. Where feasible, the easements shall
40 connect to existing and proposed recreation trails. ~~The Town shall have the right~~
41 ~~but not the obligation to plow and otherwise maintain such easements.~~

42
43 10. Road Name. Road names shall not be used which will duplicate or may be
44 confused with the names of existing roads. Road names shall be subject to the
45 approval of the Planning Board and be in compliance with the Town of Cape

1 Elizabeth Addressing Ordinance, Chapter 22, as determined by the Police
2 Chief and Town Council.

3
4 11. Road Construction Standards. Proposed roads are designed in compliance with
5 the Road Construction and Design Standards, Sec. 16-3-2.

6
7 **(e) Sewage Disposal**

8
9 The proposed subdivision will provide for adequate sewage disposal and will not
10 cause an unreasonable burden on municipal services if they are utilized. All systems
11 proposed for the disposal of sewage for developments regulated by this Ordinance
12 shall be in compliance with~~governed by~~ the provisions of the Town of Cape Elizabeth
13 Chapter 15, Sewer Ordinance, Chapter 15.

14
15 **(f) Solid Waste Disposal**

16
17 The proposed subdivision will provide for adequate disposal of solid waste. The
18 proposed subdivision will not cause an unreasonable burden on the municipality's
19 ability to dispose of solid waste, if municipal services are to be utilized.

20
21 **(g) Aesthetic, cultural and natural values**

22
23 The proposed subdivision will not have an undue adverse effect on scenic or natural
24 areas, aesthetics, historic sites, significant wildlife habitat identified by the
25 Department of Inland Fisheries and Wildlife or the municipality, or rare and
26 irreplaceable natural areas or any public rights for physical or visual access to the
27 shoreline.

28
29 1. Scenic. Consideration shall be given by the applicant and the Planning Board to
30 the impact of the proposed development on scenic vistas and view corridors to
31 and from significant natural features, historic sites, and important topographic
32 features as identified in the Town's Comprehensive Plan. ~~Structures in the~~
33 ~~proposed subdivision shall not materially obstruct existing scenic vistas and view~~
34 ~~corridors.~~ The Planning Board may consider the impact of other design features
35 such as building bulk, architectural style, building placement and landscaping to
36 ensure~~encourage~~ visual harmony, ~~between views to and from the proposed~~
37 ~~development and the surrounding neighborhood.~~

38
39 2. Wildlife. The applicant shall make adequate provision for the protection of
40 wildlife habitat and fisheries areas, which may include but are not limited to
41 maintenance of wildlife travel lanes, and the preservation and buffering of
42 wildlife habitat areas from proposed development activities.

43
44 3. Natural features. The applicant, whenever practical, shall be required to preserve
45 natural features such as water courses or bodies, existing trees of ten (10) inches
46 or more in diameter (base height), ~~marshes, swamps or other areas identified on~~

1 | ~~the official wetlands map~~, open space, scenic points, historic spots, and unusual or
2 | striking topographic features which, if preserved, would add to the attractiveness
3 | of the subdivision. ~~The Planning Board may require the applicant to dedicate such~~
4 | ~~features to joint ownership and management by the owners of individual lots~~
5 | ~~within the subdivision. In lieu of dedication to a homeowners~~
6 | ~~association/condominium association, the Planning Board may accept dedication~~
7 | ~~to the Town itself, or an appropriate non-profit third party group or organization,~~
8 | ~~such as the Cape Elizabeth Land Trust. Any dedications must be conveyed~~
9 | ~~through appropriate legal instruments, reviewed by the Town Attorney, and~~
10 | ~~approved by the Town Council.~~

11 |
12 | 4. Farmland. All farmland within the proposed subdivision shall be identified on
13 | maps submitted as part of the application.

14 |
15 | **(h) Conformity with local ordinances**

16 |
17 | 1. Comprehensive Plan. The proposed subdivision is consistent with applicable
18 | provisions of the Comprehensive Plan.

19 |
20 | 2. Zoning Ordinance. The area and width of lots shall conform to the requirements
21 | of the Zoning Ordinance. Side lot lines shall be substantially at right angles or
22 | radial to road lines.

23 |
24 | 3. Multiplex Housing. Multiplex housing and cluster developments shall be so
25 | designed, sited and laid out as to minimize disturbance of existing topography and
26 | ground cover, provide maximum usable natural or improved open space, reflect
27 | imaginative use of the site, and be compatible with any surrounding land uses and
28 | their character. The minimum lot size and density requirements for any proposed
29 | multiplex housing or cluster development shall comply with the be as set forth in
30 | Sec. 19-3-1 (d) of the Zoning Ordinance.

31 |
32 | 4. Addressing Ordinance. The street numbering of the individual residential
33 | dwelling units and/or lots must be clearly visible on the plans and shall be done in
34 | compliance with the Town of Cape Elizabeth Addressing Ordinance, Chapter
35 | 22 and shall be required to be reviewed and approved by the fire chief and police
36 | chief. For any development with more than one set of attached or multiplex
37 | dwelling units, signs clearly identifying the house numbers in each set of dwelling
38 | units shall be required to be placed along the road leading to each set of units and
39 | shall be subject to approval of the Fire Chief and Police Chief.

40 |
41 | **(i) Financial and Technical Capability**

42 |
43 | The applicant shall demonstrate adequate technical and financial capability to
44 | complete the project as proposed. In the case where the applicant asserts that public
45 | disclosure of confidential financial information may prove detrimental to the
46 | applicant or to the success of the subdivision, the Town Manager may review the

1 financial records of the applicant and recommend to the Planning Board that financial
2 capability is adequate.

3
4 **(j) Surface Waters**

5
6 Whenever situated ~~entirely~~ entirely or partially within the watershed of any pond or
7 lake or within two hundred fifty (250) feet of any wetland, great pond or river as
8 defined in Title 38 M.R.S.A. Chapter 3, subchapter I, article 2-B, the proposed
9 subdivision will not adversely affect the quality of that body of water or unreasonably
10 affect the shoreline of that body of water. The Planning Board may determine that the
11 proposed subdivision will not adversely affect surface water quality if the subdivision
12 has been designed to comply with the Shoreland Performance Overlay District.

13
14 **(k) Ground Water**

15
16 The proposed subdivision will not, alone or in conjunction with existing activities,
17 adversely affect the quality or quantity of ground water.

18
19 **(l) Flood Areas**

20
21 Based on the Federal Emergency Management Agency's Flood Boundary and
22 Floodway Maps and Flood Insurance Rate Maps, and information presented by the
23 applicant whether the subdivision is in a flood-prone area. If the subdivision, or any
24 part of it, is in such an area, the subdivider shall determine the 100-year flood
25 elevation and flood hazard boundaries within the subdivision. The proposed
26 subdivision plan must include a condition of plan approval requiring that principal
27 structures in the subdivision will be constructed with their lowest floor, including the
28 basement, at least one foot above the 100-year flood elevation. The Planning Board
29 shall review all subdivision proposals to assure that: (1) they are designed to
30 minimize flood damage; (2) all public utilities and facilities, such as sewer, gas,
31 electrical, and water systems are located, elevated, and constructed to minimize or
32 eliminate flood damage; (3) adequate drainage is provided so as to reduce exposure to
33 flood hazards; and (4) the proposed subdivision otherwise meets the standards of the
34 Town of Cape Elizabeth's Construction Code, Chapter 6, Floodplain
35 Regulations. ~~floodplain requirements.~~

36
37 **(m) Wetlands**

38
39 Any proposed alteration of wetlands shall adhere to the requirements and standards of
40 Section ~~19-2-8-19-6-9~~ and Section 19-8-33-9 of the Zoning Ordinance.

41
42 **(n) Stormwater**

43
44 The proposed subdivision will provide for adequate stormwater management.
45

1 For any subdivision involving more than ten thousand (10,000) square feet of
2 impervious surface, paving, clearing or vegetative alteration, the provisions and
3 improvements for the control of storm water runoff shall be governed by the
4 provisions of the Town of Cape Elizabeth Chapter 18, Article II, Storm Water and
5 Non-Storm Water Control Ordinance Chapter 18, Article II and Post Construction
6 Stormwater Management Ordinance, Chapter 18, Article IV. In the case of any
7 subdivision involving less than ten thousand (10,000) square feet of such impervious
8 surfaces, where a subdivision is traversed by a stream, drainage way or other
9 watercourse, or where the Planning Board with the advice of the engineer feels that
10 surface water drainage to be created by the subdivision should be controlled for the
11 protection of the subdivision and owners of property abutting it, there shall be
12 provided an easement or drainage right-of way conforming substantially with the
13 lines of such watercourse, and culverts, catch basins or other means of channeling
14 surface water within such subdivision and over the property of owner abutting upon it
15 of such nature, width and location as the Planning Board with the advice of the Town
16 Engineer, deems adequate.

17
18 **(o) Lake Phosphorus concentration**

19
20 The long term cumulative effects of the proposed subdivision will not unreasonably
21 increase a great pond's phosphorus concentration during the construction phase and
22 life of the proposed subdivision. The Planning Board may consider compliance with
23 the Great Pond Watershed Overlay District, Sec. 19-6-12, Zoning Ordinance, as
24 demonstration of no unreasonable increase.

25
26 **(p) Impact on adjoining municipality**

27
28 For any proposed subdivision that crosses municipal boundaries, the proposed
29 subdivision will not cause unreasonable traffic congestion or unsafe conditions with
30 respect to the use of existing public ways in an adjoining municipality in which part
31 of the subdivision is located.

32
33 **(q) Land subject to Liquidation Harvesting**

34
35 The proposed subdivision is not located on land where timber has been harvested in
36 violation of rules adopted pursuant to Title 12 M.R.S.A. Section 8869, subsection 14
37 or the violation occurred at least five (5) years before the subdivision application has
38 been submitted.

39
40 **(r) Access to Direct Sunlight**

41
42 Consideration shall be given by the applicant and the Planning Board to the
43 sensitivity of the proposed subdivision design for the purpose of protecting and
44 assuring access to direct sunlight. The Planning Board may, to protect and ensure
45 access to direct sunlight for solar energy systems, prohibit, restrict, or control

1 development through methods such as but not limited to restrictive covenants, height
2 restrictions, and side yard and setback requirements.

3 ~~Insofar as possible, the subdivision design shall locate structures so as to minimize~~
4 ~~shading of either existing or proposed structures. The Planning Board may consider~~
5 ~~restrictive covenants, height restrictions, side yard and setback requirements and other~~
6 ~~techniques to preserve solar access.~~

7 **(s) Buffering**

8
9
10 ~~(e)~~ ___ Plants or other types of vegetative cover shall be preserved or placed throughout
11 and around the perimeter of any proposed subdivision to provide for an adequate
12 buffer, reduction of noise and lights, separation between the subdivision abutting
13 properties, and enhancement of its appearance.

14
15 ~~(d)~~ Off-road parking lots, storage areas, rubbish disposal areas, or similar improvements
16 exposed to public roads or to residential areas shall be screened by walls, earth berms,
17 fences, or vegetation, and shall be properly landscaped.

18
19 **(t) Open Space Impact Fee**

20
21 1i. Purpose. In order to accommodate the expected needs of the subdivision for open
22 space and recreational areas without diminishing the community standard of
23 public open space, the applicant shall be required to donate land with legal public
24 access or otherwise conserved with a public benefit or a cash contribution in lieu
25 of actual land dedication, or a combination of the above both, at the option of the
26 Planning Board and with the advice of the Conservation Commission.

27
28 2ii. Community Standard. Public open space shall include the inventory of open space
29 for which there is legal public access, including:

30
31 i.(1) Open space owned by the Town;

32 ii.(2) Open space encumbered by an easement owned by the Town which allows
33 public access;

34 iii.(3) Open space owned by the Cape Elizabeth Land Trust; and

35 iv.(4) Open space encumbered by an easement owned by the Cape Elizabeth
36 Land Trust which allows public access. The Community Standard of public
37 open space shall be defined as the total acreage of open space divided by the
38 Town's population, as of the most recent U.S. Census.

39
40 3iii. ——— Land donation. The required land donation of open space shall be
41 calculated by multiplying the number of lots/units in the proposed subdivision by
42 the average number of persons per household as published in the most recent U.S.
43 Census, and then multiplying the resulting number by the Community Standard of
44 public open space. At least twenty percent (20%) of the land donated shall be land
45 which is not a Resource Protection Zone or buffer and has a slope not to exceed
46 fifteen percent (15%).

1
2 | ~~4iv.~~ Fee. If the resulting land dedication would be too small to be useful, or
3 | inappropriately located, the Planning Board may require the applicant to pay a fee
4 | in lieu of all or part of the required land dedication. The fee shall be calculated by
5 | multiplying the amount of acreage which otherwise would have been required to
6 | be donated with the proposed subdivision (rounded to the nearest one-hundredth
7 | of an acre) by the average fair market value of one acre of vacant land (rounded to
8 | the nearest dollar) determined by the Town Assessor using accepted professional
9 | valuation methods.

10
11 | 5v. Administration. ~~The type of~~ land donation and land conveyance by fee
12 | ownership deed or easement shall be consistent with the land included in the
13 | town inventory. Open space impact fees shall be segregated from the Town's
14 | general revenues and expended only for the acquisition or improvement of public
15 | open space. The Town shall refund to the applicant that portion of the collected
16 | open space impact fee that is not expended within ten (10) years from the date of
17 | receipt. The Community Standard of public open space, average fair market
18 | value of one (1) acre of vacant land, and open space impact fee therein derived
19 | shall be published in the Fee Schedule approved and periodically updated by the
20 | Town Council. The Fee Schedule shall be available for inspection at the office of
21 | the Town Clerk. Any required fee shall be paid prior to the commencement of
22 | construction of the subdivision and/or issuance of a building permit. ~~Common~~
23 | ~~open space, recreation areas or other such areas to be dedicated by the applicant~~
24 | ~~shall be maintained to ensure that its use and enjoyment is not diminished or~~
25 | ~~destroyed, with the applicant submitting written documents identifying which~~
26 | ~~individual, group or organization shall be responsible for said maintenance.~~
27 | ~~Deleted as a standard, legal transfer reflected elsewhere~~

28
29 | (u) Utility Access.

30
31 | ~~All lots shall have access to water, electrical, and telephone and other utilities. All~~
32 | ~~utilities, including but not limited to the provision of water, gas and electricity, and~~
33 | ~~the provision of solid waste disposal, shall be demonstrated to be adequate for the~~
34 | ~~proposed development.~~

35
36
37 | (v) Phasing.

38
39 | ~~If a subdivision is proposed for development in phases, no portion of the subdivision~~
40 | ~~may be left out of the phasing plan. Sequence of construction of subdivision phases~~
41 | ~~shall be determined. Each phase or, as applicable, sequence of phases shall preserve~~
42 | ~~the standards of review of Sec. 16-3-1 of this Ordinance, with emphasis on~~
43 | ~~emergency vehicle access.~~ The Planning Board may impose such conditions as it
44 | deems necessary to assure the orderly development of the subdivision, to assure that
45 | all necessary improvements are made for each separate phase.
46

1 | **Sec. 16-3-2. Road Design and Construction Standards**

2 | The purposes of the subdivision road standards are to minimize traffic safety hazards and
3 | the cost of municipal maintenance and reconstruction, to ensure that roads are consistent
4 | with the Town’s rural character, to promote a sense of community, and to be consistent
5 | with the Comprehensive Plan. The standards shall be flexible where an applicant can
6 | demonstrate that alternative approaches will meet the above stated purposes. Roads
7 | within a subdivision shall be classified by the Planning Board in accordance with their
8 | location and their present and contemplated usage. A road which is likely to be upgraded
9 | in classification in the foreseeable future shall be laid out to the standards of the potential
10 | future classification. The widths and grades for all subdivision roads shall be determined
11 | in accordance with the **Road Classification Standards Table**, subject to the following
12 | qualifications:

- 13 |
- 14 | 1. Where an existing road with right-of-way of less than fifty (50) feet is being
15 | extended, the new right-of-way may be the same width as the existing road upon
16 | approval by the Planning Board and Public Works Director/engineer.
 - 17 |
 - 18 | 2. Width of right-of-way may be forty (40) feet for a road shorter than three-hundred
19 | (300) feet which ends in a cul-de-sac, upon approval by the Planning Board and
20 | Town Engineer.
 - 21 |
 - 22 | 3. Notwithstanding the **Road Classification Standards Table**, dead-end roads in excess
23 | of one thousand (1,000) feet in length must comply with Sec. 16-3-2 (a)(9) of this
24 | Ordinance.
 - 25 |
 - 26 | ~~4. The minimum required turning radius at road intersections, unless that road is a~~
27 | ~~dead-end.~~

28 |

29 | A.(a) **_____ Road Design**

30 | 1. Sight Distance

31 |

32 | ~~a. Vehicle movements on road~~ New Subdivision Road sight distance.

33 |

34 | ~~(1) Measurement. Sight distance shall be measured from a height point 3 ½~~
35 | ~~3.5 (three and one half) feet above the pavement traveled way, in each~~
36 | ~~direction of the road to a height point 6 inches .5 (one-half) foot above the~~
37 | ~~pavement. Sight distance shall be compatible with the design speed chosen.~~
38 | ~~Isolated interruptions of minimal time duration in sight distance due to~~
39 | ~~obstructions, such as a single tree, shall not be included in the measure of~~
40 | ~~sight distance.~~

41 |

42 | ~~(2) Standard.~~ The road shall be designed to achieve a sight distance in the
43 | range indicated on the **Road Classification Standards Table**. The maximum
44 | sight distance range shall not be exceeded without reasonable justification
45 | which shall be presented by the applicant.

1
2 **b. Side road and commercial driveway entrances Road Intersections.**
3

4 (1) Measurement. The sight distance for a ~~side road or commercial driveway~~
5 entering onto a second road shall be measured from a location an eye point
6 ~~located fifteen (15)~~ feet behind the edge of traveled way of the side road or
7 drive at an elevation of three and one half (3.5) 3 1/2 feet above the finished
8 grade surface to a point four and one quarter (4.25) feet above the pavement
9 ~~paving~~ in the centerline of the travel lane approaching the intersection. Where
10 unavoidable obstructions are encountered at the fifteen (15) foot setback, the
11 point of eye location may be moved to a point no closer than ten (10) feet
12 from the traveled way. Isolated interruptions of minimal time duration in sight
13 distance due to obstructions, such as a single tree, shall not be included in the
14 measurement of sight distance.
15

16 (2) Standard. The road intersection shall be designed to achieve a sight
17 distance in the range indicated on the Road Classification Standards Table.
18 ~~shall be based on a minimum 7 second visibility time considering the~~
19 ~~approach vehicle speed to be the 85th percentile of actual measured speed~~
20 ~~with a sample large enough to be statistically valid, if such measurements are~~
21 ~~not obtained and validated shall be 100% of the posted speed limit. If the~~
22 ~~intersection can be located to achieve a 10 second visibility time, the Board~~
23 ~~may require such location to enhance safety. If truck traffic leaving the side~~
24 ~~road or drive exceeds 30% of the total traffic volume, the 10 second visibility~~
25 ~~time shall be mandatory.~~
26

27 **c. Single Family driveways entrances.** ~~When t~~ The Planning Board requires that
28 an individual driveway be shown on the subdivision plan, the shall require the
29 sight distance measurement and standard shall for a single family driveway
30 entry onto a road to meet the requirements in the Road Classification
31 Standards Table.
32

33 2. Road Geometry. New subdivision roads shall be designed to comply with the
34 Road Classification Standards Table and the following standards:
35

36 **a. Changes in Direction Horizontal Alignment.** At all changes in alignment,
37 road sidelines shall be connected by horizontal curves. All changes in slope
38 shall be connected with vertical curves whose length shall be consistent with
39 the **Road Classification Standards Table.** When the degree of curvature
40 exceeds two (2) degrees on rural connector, collector, or arterial roads, the
41 curves shall be super-elevated to meet the criteria established by AASHTO,
42 1984 most current Edition, or as the same may be revised or amended.
43

44 **b. Intersection Design Entry Grades**
45

1 | a. ~~(1)~~ Roadway grades approaching an intersection shall not exceed three (3)
2 | percent% for a distance of fifty (50) feet from the edge of paving of the
3 | road being entered.

4 |
5 | ~~b. Driveway entrance grades shall meet the following criteria:~~
6 | ~~High Volume Commercial Drives: 3% Max for 30 feet~~
7 | ~~Low Volume Commercial Drives: 4% Max for 20 Feet~~
8 | ~~Single Resident Drives: 6% Max for 10 Feet~~
9 |

10 | ~~14. Jogs . Road jogs at (2) Road i~~intersections shall be separated at
11 | least with centerline offsets of less than one hundred twenty-five (125)
12 | feet whenever possible shall be avoided. Move to #10, separate
13 | intersections at least 125'. A separation of less than one hundred twenty-
14 | five (125) feet may be acceptable when a low volume of traffic allows for
15 | safe traffic circulation.
16 |

17 | (3) At intersections and common boundaries of subdivisions, roads shall be
18 | continuous and in alignment with existing roads if possible. Roads shall be
19 | laid out so as to intersect as nearly as possible at right angles, and no road
20 | shall intersect any other road at less than a sixty (60)-degree angle.
21 |

22 | c. Traveled Way-. The traveled way shall be designed consistent with the
23 | Road Classification Standards Table. Every traveled way shall maintain a
24 | constant width and shall be centered in its right-of-way. ~~No waiver of this~~
25 | ~~requirement shall be granted except in writing by the Town Manager or by the~~
26 | ~~Planning Board, and only before the start of construction of the road bed. The~~
27 | ~~Planning Board may also shift the traveled way up to five (5) feet from the~~
28 | ~~center to preserve existing mature trees or minimize wetland alterations.~~
29 |

30 | d. Radii. Radii of curves and lengths of tangents between curves shall be
31 | consistent with the **Road Classification Standards Table.** At a minimum,
32 | road radii shall provide adequate turning radius for a B-40 vehicle as defined
33 | by AASHTO. To measure turning radius, the full width of pavement of both
34 | lanes of traffic shall be included, exclusive of shoulder areas. Minimum
35 | turning radius shall be required from both directions of the intersecting road.
36 | ~~and such radii shall not be less than 20 feet for all inside corners.~~
37 |

38 |
39 | e. Shoulders-. The width of shoulders and surfacing shall be determined by
40 | reference to the **Road Classification Standards Table.** The road lanes shall
41 | be striped to provide a traveled way in compliance with the **Road**
42 | **Classification Standards Table.**
43 |

44 | 3. Sidewalks-. Sidewalks shall be five (5) feet wide and shall be separated from the
45 | traveled way by a grassed esplanade in accordance with the **Road Classification**
46 | **Standards Table.** When locating the sidewalk, a one (1) foot wide buffer strip

1 shall be preserved along the right-of-way between the back edge of the sidewalk
2 and the right-of-way. Sidewalks shall be required on one side of the road and
3 notwithstanding Sec. -16-3-5 of this Ordinance, shall not be waived by the
4 Planning Board. The design of a Rural Connector shall include a sidewalk path
5 within ten (10) feet of the outside edge of the right-of-way. The sidewalk path
6 shall be field located to avoid significant vegetation. ~~(Revised eff 12/10/03)~~

7
8 4. Curbing-

9
10 a. Installation. Curbing shall be installed ~~At~~ road intersections ~~all curbing shall~~
11 ~~be granite~~ and have a radius of at least twenty-five (25) feet, unless otherwise
12 approved by the Town Engineer. Curbing ~~shall may~~ be required to aid in
13 slope stabilization. ~~(Revised eff 12/10/03)~~

14
15 b. Material. Curbing shall consist of granite, extruded concrete or bituminous
16 concrete; design and choice of materials for curbing shall be based upon the
17 anticipated use of the road involved and shall be subject to the approval of the
18 Town Engineer and the Public Works Director. Granite curbing
19 specifications shall be ~~five six~~ inch by ~~eighteen seventeen (5 x 17)~~ inch vertical
20 plus or minus one (1) inch vertical or eight inch by twelve inch sloped curb as
21 required by the ~~Director of~~ Public Works Director. Granite curbing installed at
22 intersection shall be set in concrete.

23
24 5. Drainage. All roads shall have an underground enclosed drainage system, and no
25 surface drainage shall be conveyed or diverted across a traveled way. ~~(Revised~~
26 ~~effective 12/10/03)~~

27
28 6. Road Signs. Road ~~name~~ signs shall be approved by the Public Works Director and
29 installed in compliance with MUTCD (Manual on Uniform Traffic Control
30 Device) standards by the Public Works Department, unless the applicant desires
31 alternative means of street identification. Any alternative method must be
32 approved by the Planning Board.

33
34
35 7. Road Trees-

36
37 a. Adjacent to Road. Each road shall be designed to include, within the right-
38 of-way, at least one (1) tree for every forty (40) feet of road frontage but not
39 less than two (2) trees per lot. All trees shall comply with tree species and size
40 standards approved by the Town Tree Warden. Existing trees within the right-
41 of-way which have been preserved may be counted toward this requirement if
42 the species, size, preservation measures, and post-construction condition of
43 the trees are approved by the Tree Warden. Where an esplanade is included in
44 the road design, road trees required on that side of the street shall be planted in
45 the esplanade. The esplanade shall be filled with soil, such as common
46 borrow, suitable for growing trees. See also Appendix C, Road Tree List.

1
2 **b. Cul-de-sac.** Landscaping including trees and other plant materials shall be
3 required in the center island of a cul-de-sac. ~~(Revised eff. 12/10/03)~~

4
5
6 **8. Dead-End Roads.** ~~[Revised Effective 6/12/91 i. iv]~~

7
8 **ii.a. Length.** Dead-end roads shall not be longer than two thousand (2,000)
9 feet in length and shall not serve more than twenty (20) dwelling units. The
10 maximum length, the maximum number of dwelling units and the mandatory
11 requirements of dead-end roads shall not be waived by the Planning Board,
12 notwithstanding the waiver provision in Sec. 16-3-5 of this Ordinance. ~~[Rev.~~
13 ~~eff. 7/13/94]~~

14
15 **iii.b. Minimum Requirements.** Any dead-end road in excess of one thousand
16 (1,000) feet in length shall meet mandatory requirements for the entire length
17 of the dead-end road. Mandatory requirements shall include (1) the placement
18 of all utilities underground, (2) the dedication to the Town of a fifty (50) foot
19 wide right-of-way, and (3) a minimum pavement width of twenty-two (22)
20 feet. ~~(revised effective 12/10/03)~~

21
22 **c. Added Requirements.** The Planning Board may require improvements such
23 as (1) the placement of sidewalks to Town specifications, (2) limited clearing
24 of the right of-way with the advice of the Town Tree Warden on the
25 stability of adjacent tree growth, (3) the provision of an emergency access
26 lane with a minimum width of eighteen (18) feet and (4) a minimum
27 esplanade width of six (6) feet for divided entrances.

28
29 **d. —Measurement.** A dead-end road shall be measured from the end of the
30 existing or proposed dead-end road to the closest intersecting through road.
31 The measurement shall include proposed road(s) and existing road(s), public
32 or private, whether within or beyond the limits of the proposed subdivision.
33 The length of the road shall be measured from the center line of the closest
34 through road, along the center line of the dead-end road to the end of
35 pavement or traveled way. Divided entrances shall be allowed only if they
36 provide direct access to arterial roads as classified by the Town. ~~[Rev. eff.~~
37 ~~7/13/94]~~

38
39 **e. —Termination.** All dead-end roads shall end in a cul-de-sac or a T-shaped
40 turnaround and be designed according to the dimensions shown on Appendix
41 D.the attached diagrams. All cul-de-sacs shall be so designed that water will
42 drain from all portions into a storm water drainage system. The interior of all
43 cul-de-sacs shall be neat and orderly, and shall either be left in its natural
44 condition or be graded, loamed and seeded. Granite monuments shall be
45 installed by the developer at the intersection of each side of the road with the

1 cul-de-sac and at the radius point of the cul-de-sac, as shown in the cul-de-sac
2 diagrams.

3
4 A T or L-shaped turnaround may be used and placed on the right side of the
5 road., only after a written approval of its location and design by the Director
6 of Public Works has been provided, to be constructed as follows:

7 All T-shaped turnarounds, whether temporary or permanent, shall be paved.
8 No parking is allowed in a turnaround. See also Appendix D, Turnaround
9 Design, and at no time shall any portion of the turnaround be incorporated into
10 a private driveway, a private road or any access road. All T-shaped
11 turnarounds shall be posted with “No Parking” signs by the developer with
12 approval of the Public Works Director. Any temporary turnaround must be
13 paved.

14
15 9. Private Road. A private road shall enter a road at the level of the edge of the
16 traveled way, and shall have a slope of 3% or less within the right-of-way. The
17 first fifty (50) feet² of a private road from the edge of the road shall be paved. A
18 private road shall be constructed in accordance with the right-of-way width,
19 gravel base, traveled way width and monumentation of a local road. The Planning
20 Board may require that a road be constructed to public road standards; further the
21 Planning Board shall require dedication of the roads as public rights-of-way if
22 there is potential for future development that could be accessed through the
23 proposed subdivision.

24
25 10. Monuments. A four (4) inch square granite monument shall be set at each point
26 of curvature and angle point on both sides of every road and at every property line
27 intersection. A surveyor’s pin shall be set at each property line corner. Except
28 with the permission of Public Works Director, all monumentation shall set flush
29 with existing grade. At road intersections and at locations where monuments on
30 one road line would fall within two hundred (200) feet of each other, the Public
31 Works Director may reduce this requirement provided that the reduced
32 monumentation is adequate for road line surveys. (Revised eff. 12/10/03)

33 34 35 **B(b) Road Construction**

36 1. Clearing

37
38 a. Prior to site alteration, a land surveyor registered in the State of Maine shall
39 mark the layout of the road and verify for the Town Engineer that the layout is
40 in conformance with the approved plans.

41
42 bi. The construction area shall be selectively cleared of all trees, brush and
43 vegetation only as necessary for construction of the roadway, shoulder,
44 utilities and any drainage ways as approved by the Planning Board. Clearing
45 provisions shall be accomplished in accordance with the most recent revision

1 of the Standard Specifications of the Maine Department of Transportation,
2 Section 201.

3
4 **ii.** Limits of clearing shall be marked in the field and may be inspected by the
5 Town Engineer prior to further any clearing or grubbing of the site
6 preparation. In a Rural Connector, a ten (10) foot²-wide strip shall be
7 preserved at the edge of the right-of-way, where a sidewalk path may be
8 placed. The ten (10) foot wide strip shall be retained in a natural state and
9 serve as a buffer, although trimming may be allowed to preserve scenic views.

10
11 2. Grading to Subgrade

12
13 **i.**—The roadway shall be brought to subgrade through the process of excavation
14 and/or placement of fill. Such earthwork shall be accomplished in compliance
15 with the technical provisions of Section 203 of said MDOT Specifications.
16 Blasted ledge, which is, less than fourteen (14) inches in any dimension, may be
17 used as fill up to a level one foot and one-half (1.5) feet six inches below
18 subgrade, and shall be mixed with sufficient finer material to make a firm, stable
19 embankment. Revised eff. 12/10/03)

20
21 3. Base Gravel for Roadways & Sidewalks

22
23 **ai. Base Course.** ~~The Aggregate~~ gravel base course shall be a minimum of one
24 and one-half (1.5) feet ~~1-foot 6 inches~~ in depth. When subgrade materials are
25 marginal, the Town Engineer may require additional base gravel. The lower
26 12 inches one (1) foot of material shall conform to the requirement of Section
27 703.06 (b). Types D or E of the said MDOT Specifications, except that no
28 particle of rock shall exceed three (3) inches as determined by a three (3) inch
29 square mesh sieve.

30
31 **ii.b. Upper Course.** The upper six (6) inches of material shall conform to the
32 requirements of Section 703.06 (a). Types A and B of ~~the~~ said MDOT
33 Specifications except that ~~m~~Maximum particle size for Type B shall be three
34 (3) inches.

35
36
37 **iii.c. Compaction.** The base gravel shall be placed and compacted in
38 accordance with technical requirements of Section 304 of said MDOT
39 Specifications. Initial compaction tests shall be taken at a minimum interval
40 of every fifty (50) linear feet along the roadway for each lift of material
41 placed, and then compaction tests at a greater separation if initial tests pass.
42 Retesting of any failed areas must be conducted after remedial action has been
43 accomplished. Additional compaction tests may be required by the Public
44 Works Director.

iv.d. Sidewalk. Gravel for sidewalk base shall be eight (8) inches in depth and shall meet the requirements of Section 703.06 (a) of said MDOT specifications, Types ~~A, or B~~, or D, placed in one lift compacted to ninety-five (95) percent% of optimum density.

v.e. Esplanade. The base of the esplanade located between the road and the sidewalk shall not be filled with gravel. The underlying material under the loam layer shall be common borrow or a similar material conducive to tree growth. The maximum grade of the esplanade cross-slope shall be two (2) percent%.

4. Paving.

ai. HMA. Paving shall be of ~~bituminous concrete~~ Hot Mix Asphalt (HMA) meeting the requirements of Section 401 and 403 of said MDOT Specifications. Placement of ~~pavement~~ HMA shall conform to MDOT Specifications (Section 401). Sidewalk ~~pavement~~ HMA shall be placed in two (2) one and one quarter (1.25) inch lifts using "D" 9.5 mm mix. ~~Pavement~~ HMA thickness shall be as follows:

	Base Course <u>("B" Mix)</u> <u>19 mm Mix</u> <u>unless</u> <u>otherwise</u> <u>noted</u>	Surface Course <u>("C" Mix) 12.5</u> <u>mm Mix,</u> <u>except local</u> <u>roads which</u> <u>shall be</u> <u>9.5 mm</u>	Surface Course <u>("D" Mix) 9.5</u> <u>mm fine Mix</u>	Total
Arterial	<u>2.5 inches"</u>	<u>1.5- inches-</u> <u>1/2"</u>	--	<u>4 3-1/2</u> <u>inches"</u>
Collector	<u>2.5 inches"</u>	<u>1.5- inches-</u> <u>1/2"</u>	--	<u>4 3</u> <u>1/2inches"</u>
Rural Connector	<u>2.5 inches"</u>	<u>1.5- inches-</u> <u>1/2"</u>	--	<u>4 3</u> <u>1/2inches"</u>
Feeder	<u>2.5 inches"</u>	<u>1.5 inches-</u> <u>1/2"</u>	--	<u>4 3</u> <u>1/2inches"</u>
Local Roads	<u>2.5 inches"</u> <u>of 19 mm</u>	<u>1.5 inches-</u> <u>1/2"</u>	--	<u>4 3</u> <u>1/2inches"</u>
Sidewalks	--	--	<u>2.5 inches"</u>	<u>2.5 inches"</u>

(Table revised 12/10/03)

ii.b. Base Course. The HMA base course shall be Gradation B-19 mm mix for all classes of roads, except local roads and sidewalks which shall be 9.5 mm mix as defined in Section 703.09 of said MDOT Specifications. ~~Surface course shall be Gradation C.~~ Sidewalk paving shall be Gradation D 9.5 mm (fine) mix.

1 | iii.c. Placement. Placement of all HMA paving shall be in compliance with the
2 | technical requirements of Section 401 of said MDOT Specifications.

3 |
4 | d. iv. Driveways. Driveway entrances shall ~~be include~~ a paved ~~apron to the road~~
5 | ~~line starting at the edge of road pavement and extending four (4) feet toward~~
6 | ~~the property being served. In locations where driveways are coincident with~~
7 | ~~sidewalks, the paved apron shall extend from the edge of the road pavement to~~
8 | ~~four (4) feet beyond the back of the sidewalk. Driveway aprons shall meeting~~
9 | the criteria for ~~—minor local~~ road paving.

10 |
11 |
12 | e. Curb Platform. ~~v.~~ Where bituminous or extruded concrete curbing is
13 | to be placed, the paving shall extend ~~6 inches one (1) foot~~ beyond the back of
14 | curb to serve as a curb platform.

15 |
16 | 5. Curbing. ~~Bituminous concrete curbing~~ Curbing shall be placed in accordance
17 | with Section 609 of ~~the~~ said MDOT Specifications. Bituminous concrete
18 | ~~c~~ Curbing shall meet the requirements of Section 712.36 of said MDOT
19 | Specifications. Extruded concrete curbing shall meet the requirements of Section
20 | 712.03 of said MDOT specifications. The curb cross section shall be of the low
21 | profile berm curb type and shall be placed on top of the HMA base course. ~~base~~
22 | ~~course "B". (Revised eff. 12/10/03)~~

23 |
24 | 6. Stone Fill, Riprap, Stone Ditch Protection. When required for erosion control,
25 | stone fill, riprap and stone ditch protection shall be placed in accordance with
26 | Section 610 of ~~the~~ said MDOT Specifications.

27 |
28 | 7. Sodding - Erosion Control Mesh.

29 | i. Where required to prevent erosion and when indicated on the plans, sod shall
30 | be placed in accordance with the technical requirements of Section ~~616626~~ of
31 | said MDOT Specifications.

32 | ii. When required to prevent erosion and where indicated on the plans, erosion
33 | control mesh shall be placed in accordance with the technical requirements of
34 | Section ~~6136117~~ of said MDOT Specifications.

35 |
36 | 8. Seeding.

37 | i. All exposed slopes and areas not to be paved shall be seeded in accordance
38 | with the technical requirements of Section 618 of said MDOT Specifications.
39 | Seeding Method 1 shall be used.

40 | ii. Mulch shall be applied to all seeded surfaces in accordance with the technical
41 | requirements of Section 619 of said MDOT Specifications.
42 |

1
2

Road Classification Standards Table

	Right of Way	Traveled Way	Total Width of Pavement Minimum Intersection Sight Distance	Width Unpaved Shoulder	Horizontal Sight Distance	Design Speed	Sidewalk	Esplanade	Center Line Radius
ARTERIAL (unpaved shoulders)	52' -	28' -	30' -	2' -	200-400 -	30-45 -	5'(1) -	5' -	300-800 -
ARTERIAL (paved shoulders)	52'	248'	<u>36'</u> <u>200'</u>	<u>5'</u>	200-400	30-45	5' (1)	5'	300-800
COLLECTOR (unpaved shoulders)	50'	24'	<u>26'</u> <u>200'</u>	1'	200-250	30-35	5' (1)	6'	300-400
COLLECTOR (paved shoulders)	50' -	24' -	26' -	0' -	200-250 -	30-35 -	5'(1) -	6' -	300-400 -
RURAL CONNECTOR	66'	24'	<u>26'</u> <u>200'</u>	4'	200-250	30-35	5'	7'	300-400
FEEDER	50'	24'	<u>24'</u> <u>150'</u>	<u>03'</u>	150-200	25-30	5'	<u>75'</u>	150-300
LOCAL	50'	22'	<u>22'</u> <u>125'</u>	<u>04'</u>	125-150	20-25	5'	<u>86'</u>	125-150
(1) Either sidewalk or bikeway. Width should increase for dual purpose									

3
4
5

Table Revised eff. (12/10/03)

See also Appendix E, Road Profiles

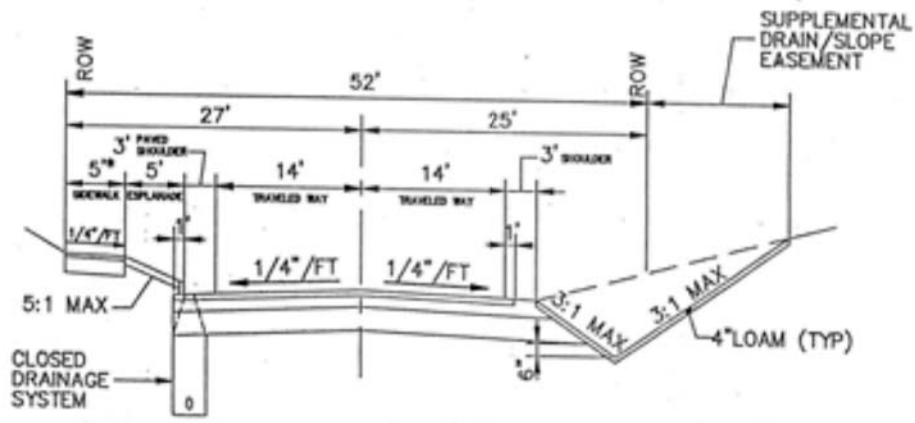

• SEE ROAD CLASSIFICATION STANDARDS TABLE

ARTERIAL (UNPAVED SHOULDERS)
NOT TO SCALE

1 |



2 |

1 |
2 |

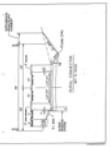



1
2

1 |
2 |



1 |

2 |

100

1 |

2 |



1 |
2 | **Sec. 16-3-3. Design of Other Improvements**
3 |

4 | **A.(a) Storm and Surface Water Drainage**

- 5 | 1. Storm water collection and transport systems shall comply with the Town of Cape
6 | Elizabeth Stormwater and Non-Stormwater Control Ordinance, Chapter 18, Article II
7 | and the Town of Cape Elizabeth Post Construction Stormwater Management
8 | Ordinance, Chapter 18, Article IV.~~be designed to carry a 25 year return frequency~~
9 | ~~flow without surcharge.~~
10 |
11 | 2. Ditches, where permitted, on the approved plans shall have a slope of at least two (2)
12 | percent% and side slopes not exceeding three to one (3:1). Where required to prevent
13 | erosion, ditches shall be riprapped, sodded, or otherwise protected.
14 |
15 | 3. Storm drain pipelines and culverts shall be installed in accordance with the technical
16 | requirements of Section 603 of said MDOT Specifications. All pipes shall be
17 | designed to withstand earth backfill plus H-20 wheel loadings. Trench backfill over
18 | drain lines within the paved way shall be compacted to ninety-five (95) percent% of
19 | optimum density. Outside of paved areas backfill shall be compacted to ninety (90)
20 | percent% of optimum density.
21 |
22 | 4. When required to assure a stable subbase, rigid perforated underdrain pipe shall be
23 | installed in accordance with the technical requirements of Section 605 of said MDOT
24 | Specifications. Coiled underdrain pipe will not be permitted. (Revised eff. 12/10/03)
25 |
26 | 5. Manholes and catch basins on storm drain lines shall meet the technical requirements
27 | of Section 604~~5~~ of said MDOT Specifications. Shop drawings for the units desired for
28 | use shall be submitted to the Town Engineer for approval prior to placement.
29 |
30 | ~~6. It is specifically noted that all drainage facilities must also comply with the~~
31 | ~~requirements of the Town Storm Water Management Ordinance.~~
32 |

33 | **B.(b) Underground Utility Lines**

- 34 | 1. All sanitary sewer lines and appurtenances shall be constructed in accordance with
35 | the requirements of the Town of Cape Elizabeth Sewerage Ordinance, particularly
36 | Sec. 15-1-6 and 15-1-7.
37 |
38 | 2. Any road to be accepted shall be served by a water main if said road joins a road
39 | containing a water main. No water main shall be less than eight (8) inches² in
40 | diameter unless the fire department and the Planning Board certify in writing that a
41 | water main less than eight (8) inches² in diameter will furnish adequate water service
42 | for the road to be accepted and for any future extension of said road.
43 |

- 1 3. All underground utility mains shall be installed before the gravel surface is placed;
2 and, if possible utility service lines to individual lots shall be installed before gravel
3 surface is placed.
4
- 5 4. Backfill materials for all underground utilities shall be compacted to ninety-five
6 (95)% percent of optimum density under paved areas and to ninety (90) percent% of
7 optimum density under non-paved areas.
8

9 **Sec. 16-3-4. Additional Standards**

10 (a) **Right-of-Way.** The Planning Board with the advice of the Town Engineer may
11 require rights-of-way wider than those set forth in the **Road Classification**
12 **Standards Table**, in order to satisfy the purposes of this Ordinance.
13

14 (b) **Reserved**

15

16 (c) **Sewers .** Upon the advice of the Town Engineer, the Town Council may require an
17 applicant to construct storm or sanitary sewers at a greater depth or of larger diameter
18 than is required to serve the area being subdivided, ~~when~~
19 said greater depth or larger diameter is deemed necessary to provide proper service
20 for adjacent areas.
21

22 **Sec. 16-3-5. Waivers** Where the Planning Board finds that undue hardship, practical
23 difficulties or restriction upon imaginative and otherwise desirable design may result
24 from strict compliance with this Ordinance, it may waive one or more of the requirements
25 of this Ordinance, in favor of a proposed alternative upon a showing that, as compared
26 with strict compliance, such alternative (1) will not create more hazardous traffic
27 conditions or less sanitary sewage disposal conditions than strict compliance, (2) will
28 provide more varied and imaginative subdivision layout and design, (3) will secure
29 substantially the standards of road design and construction required by this Chapter and
30 the Zoning Ordinance, and (4) will not have the effect of nullifying the intent and
31 objectives of the Comprehensive Plan or this OrdinanceChapter; provided that in granting
32 such waiver the Planning Board may impose such conditions as they deem necessary to
33 secure the foregoing objectives.
34

35 **Sec. 16-3-6. Legal Provisions**

36 (a) **Appeals-** All appeals from decisions of the Planning Board under this Ordinance~~the~~
37 ~~subdivision regulations~~ and the Zoning Ordinance shall be taken within thirty (30)
38 days following the date of any such decision in accordance with the provisions of
39 Rule 80B of the Maine Rules of Civil Procedure. This procedure shall apply whether
40 or not the appeal involves issues requiring an interpretation of the Zoning Ordinance.
41

42 (b) **Applicability of Road Requirements.** The provisions of ~~this~~the subdivision
43 Ordinance~~regulations~~ shall serve as a guide to, but shall not be binding upon, any
44 state, county or municipal body or authority, which may lay out, alter, widen or
45 improve any public way in accordance with the applicable statutes. ~~This~~isese

1 | ~~subdivision-Ordinance regulations~~ shall not apply to any roads within the Town for
2 | which road profiles had been approved by the ~~Town E~~ngineer prior to March 13,
3 | 1968, which were under actual construction as of March 12, 1968 and which had been
4 | completed not later than October 14, 1968.

5 |
6 | **(c) Amendments to the Subdivision Ordinance-** This ~~O~~rdinance may be amended by
7 | the Town Council following the procedure outlined in Sec. 19-4-9 of the Zoning
8 | Ordinance.

9 |
10 | **(d) Historical Interpretation.** This Ordinance replaces the Subdivision Ordinance as
11 | amended through 12-10-2003. Most of the prior ordinance provisions have not been
12 | substantively changed and have been brought forward into this Ordinance. When that
13 | is the case, the interpretation by the Town of the provision in the prior ordinance is
14 | carried forward to this Ordinance.

1
2 **Appendix A**

3 **Minor Subdivision Submission Requirements**

4 A. General submission parameters.

5 ~~The subdivision plan~~An application for a Minor Subdivision shall consist of fourteen
6 ~~fifteen- (145) sets copies of plans one or more maps or drawings~~ drawn to a scale of not
7 ~~more no larger~~ than forty (40) feet to the inch and supporting materials, ~~which shall be~~
8 ~~legibly reproduced on a durable material or clearly drawn in ink on mylar and~~ The size
9 of ~~the plan~~ sheets submitted to the Planning Board shall ~~in no case~~ be no larger than
10 twenty-four (24) x thirty-six (36) inches, but may be smaller with the permission of the
11 Planning Board at the discretion of the developer. ~~(Revised eff. 12/10/03)~~ A digital copy
12 of the complete application shall also be made available upon request.

13 ~~Such sheets shall have a margin of two (2) inches outside of the border lines on the left~~
14 ~~side for binding and a one (1) inch margin outside the border along the remaining sides.~~
15 ~~Space shall be reserved thereon for endorsement by all appropriate agencies.~~

16 B. List of Submission items.

17 The application for approval of a Minor Subdivision shall include all the following
18 information. Information that must be shown on a plan is in bold type.:

- 19 1. Right, Title or Interest. ~~E~~evidence of right, title or interest in the site of the proposed
20 subdivision. ~~name and address of record owner and applicant, and names of adjoining~~
21 ~~property owners.~~
- 22
23 2. Name of Subdivision/Applicant. ~~Proposed name of the subdivision, -or identifying~~
24 ~~title, and~~ name and address of record owner and applicant, names of adjoining
25 ~~property owners, and~~ The date of submission, north point, and graphic map
26 ~~scale.~~
- 27
28 3. Survey. ~~—An actual field survey of the boundary lines of the tract~~ A standard
29 boundary survey of the site, giving complete descriptive data by bearings and
30 ~~distances, made and certified by a licensed land surveyor.;~~ a copy of the deed for
31 the property to be developed, as well as copies of any easements, restrictions or
32 covenants; ~~The corners of the tract shall be located on the ground and marked by~~
33 ~~monuments as herein required, and shall be referenced as shown on the Plan. The~~
34 ~~survey a plan shall showing the number of the lot, -dimensions of area and~~
35 ~~building envelope of each proposed lot; existing easements; ; and building lines~~
36 ~~pertaining to the proposed subdivision and to the adjacent properties; 5.~~
37 ~~—~~ Location mMap, showing the relative location of the proposed project in
38 relation to surrounding neighborhoods or areas of ~~the~~ Town; ~~6.7.~~ sSufficient
39 data to determine readily the location, bearing and length of every lot line, and
40 ~~boundary line and to reproduce such lines upon the ground. Where practical these~~
41 ~~should be tied to reference points previously established.~~

42
43 4. Water Pollution evaluation.

1
2 **a. Topography.** Contour lines at intervals of two (2) feet or at such intervals as
3 the Planning Board may require, based on United States Geological Survey
4 datum, referenced to mean sea level;

5
6 **b. Surface drainage.** Surface drainage patterns including drainage channels and
7 watershed areas; ~~shall be shown~~ the slope of the land and its effect on effluents;
8 the availability and condition of streams used for disposal of effluents; an
9 evaluation of applicable state and local health and water resource rules and
10 regulations.

11
12 **c. Soils. 10.**—A soils report identifying the soils boundaries and names in the
13 proposed development with the soils information superimposed upon the plot
14 plan in accordance with the USDA Soil Conservation Service National
15 Cooperative Soil Classification; ~~The Board may require a high intensity soil~~
16 ~~survey prepared by a soil scientist certified by the State of Maine which will~~
17 ~~identify changes in soils conditions down to one eighth of an acre, along with~~
18 ~~detailed map unit descriptions. A lot by lot soils suitability determination for~~
19 ~~housebuilding with septic sewage disposal may also be required by the Planning~~
20 ~~Board.~~

21
22 **d. Air.** Description of any air emissions not normally included in residential
23 construction and use activities.

24
25 **5. Potable Water.** Confirmation of a clean and adequate supply of water to serve the
26 subdivision; the location and size of any existing and proposed water mains on
27 the property and adjacent water lines that will provide water supply for the
28 property to be subdivided, as well as details showing connections to water
29 systems; nearest hydrant; Where public water is not to be provided, an
30 alternative means of a clean and adequate water supply shall be shown.

31
32 **6. Erosion.** A soil erosion and sediment control plan ~~shall be~~ prepared and certified by a
33 professional geologist or professional engineer.

34
35
36 **7. Traffic. 3.**—Locations, widths and names of existing, filed or proposed roads,
37 cross-sections of the proposed grading for roadways, sidewalks, etc. including
38 width, type of pavement, elevations and grades, preliminary designs of any
39 bridges or culverts which may be required, designed to comply with the Road
40 Design and Construction Standards, Sec. 16-3-2; a traffic study evaluating the
41 capacity of adjacent roads to safely accommodate the anticipated traffic generated by
42 the proposed subdivision, including an assessment of the likelihood of cut-through
43 traffic, efforts to provide for road connectivity, and applicability of the Maine
44 Department of Transportation regulations.

1 8. Sewage Disposal. All on site public or shared sewage and water supply facilities
2 shall be shown and designed to meet the minimum specifications of these standards
3 and all pertinent state and local ordinances. Compliance shall be stated on the Plan
4 and signed by a licensed site evaluator. If a private sewage disposal system is
5 proposed, location and results of tests to ascertain subsurface soil and ground water
6 conditions and depths to maximum ground water level. A completed HHE 200 form
7 or other subsurface wastewater design for every lot not served by public sewer; all
8 designs, specifications and details for a clustered private or public sewer
9 system, must be submitted with the application for approval as well as designs and
10 location of any culverts which may be required.

11
12 9. Solid Waste Disposal. Demonstration of adequate capacity for disposal of
13 construction and solid waste to be generated by the subdivision.

14
15 10. Aesthetic, cultural and natural information. Location of scenic, unique natural,
16 farmland, parkland, historic, and significant wildlife habitat areas located on or
17 adjacent to the proposed subdivision, as well as supporting documentation.

18
19 11. Local regulations. 4. — The boundaries and designations of zoning districts;
20 applicable space standard and setback provisions, and evaluation of the
21 proposed subdivision's compliance with applicable provisions such as Open
22 Space Zoning (Sec. 19-7-2).

23 ~~parks and other public spaces.~~

24
25 12. Financial and Technical Capability. 13. — Statement of Technical and Financial
26 Capability, including a list of the applicant's development consultants, a description
27 of all prior development projects, and a letter of firm financial commitment from a
28 bank or other source of financing. In the case where the applicant asserts that public
29 disclosure of confidential financial information may prove detrimental to the
30 applicant or the project, the applicant may substitute a recommendation from the
31 Town Manager that the applicant has adequate financial capability to complete the
32 project.

33
34 13. Surface Waters. Location of any portion of the subdivision in the Shoreland
35 Zone; identification of the normal high water line; assessment of how water
36 quality will be impacted by anticipated discharge from the subdivision.

37
38 14. Ground Water. An assessment of how the proposed subdivision will impact
39 groundwater resources.

40
41 15. Floodplain. Location of any portion of the subdivision in the floodplain;
42 assessment of how construction in the floodplain will comply with the Town of Cape
43 Elizabeth Construction Code, Chapter 6, Floodplain Ordinance, Sec. 6.

44
45 16. Wetlands. The boundaries of all wetlands in accordance with the Zoning
46 Ordinance; an assessment of how any alterations of wetlands will comply with The

1 Town of Cape Elizabeth Zoning Ordinance, Chapter 19 local wetland regulations,
2 Sec. 19-67-9.

3
4 17. Stormwater/Phosphorus. 12. — A surface drainage plan or stormwater
5 management plan, with profiles and cross sections drawn by a professional
6 engineer, registered in the State of Maine, showing preliminary design of all
7 facilities and conveyances necessary to meet the stormwater management
8 standards as set forth in this ordinance. Where the subdivision includes or abuts
9 Great Pond, an assessment of phosphorus loading amounts and impacts on Great
10 Pond.

11
12 18. Liquidation Harvesting. Identification of any portion of the subdivision where
13 timber has been harvested in violation of Title 12, section 8869, subsection -14.

14
15 19. Landscaping. An inventory of existing vegetation to be preserved; methods of
16 preserving vegetation to be used during construction; a landscaping plan including
17 planting locations, plant types, quantities and size and time of planting; fencing
18 location, type and material and size.

19
20 20. Open Space. Designation on the plan of land to be permanently protected as open
21 space; calculation of open space provided to meet the Open Space Impact Fee
22 (Sec. 16-3-1(t)); ~~Written evidence of all location of easements; fee interest or~~
23 easements ~~deeds~~ of open space to be conveyed to the Town or otherwise conserved;
24 and ~~public open space shown on the Plan to be dedicated to the Town, the~~
25 development's association, or any other third party, and ~~copies of agreements or other~~
26 documents showing the manner in which these spaces are to be maintained.

27
28 21. Utilities. 14. — Evidence of the capacity to provide ~~E~~lectrical and telephone
29 facilities.

30
31 22. Phasing. A phasing plan showing the boundaries and name of each phase.

32
33
34 ~~8. The survey of the outside boundaries of the tract and the computation of the lot lines~~
35 ~~shall be performed to an accuracy of one foot in 5,000 feet. If requested by Planning~~
36 ~~Board, the surveyor shall furnish copies of computation sheets for outside boundaries~~
37 ~~showing:~~

38 ~~A. Sketch of traverse line;~~

39 ~~B. Closures;~~

40 ~~C. Adjustments;~~

41 ~~D. Coordinates; and~~

42 ~~E. Computation of outside boundaries.~~

43
44
45 ~~11.~~

1
2
3 | ~~15. A copy of such covenants or deed restrictions as are intended to cover all or part of~~
4 | ~~the tract.~~

5
6 | ~~23. 16. Related information.~~ Any other data as determined by the Planning Board to
7 | ascertain compliance with this Ordinance.

8
9 | ~~17. There shall be submitted to the Planning Board with the Final Plan:~~

10 | ~~a.—~~

11 | ~~b.— Written evidence that the Town Manager and the Town Attorney are satisfied~~
12 | ~~with the legal sufficiency of the documents referred to in Paragraph (a) above~~
13 | ~~when review is deemed necessary by the Planning Board. Such written evidence~~
14 | ~~shall not constitute an acceptance by the municipality of any public open space~~
15 | ~~referred to in this Appendix.~~

16
17 | ~~e.— Written evidence of the offer and conditional municipal approval by the Town~~
18 | ~~Council of all roads, sewer lines, drainage easements, proposed public open~~
19 | ~~space, recreation land, and other such common areas and facilities proposed to be~~
20 | ~~dedicated to the Town.~~

21
22 | ~~d.— A Subdivision Plat suitable for recording which includes a prominent notation~~
23 | ~~that there shall be no sale of lots, nor issuance of building permits, not site work~~
24 | ~~commenced until the required performance guarantee has been approved by the~~
25 | ~~Town Manager.~~

1
2 **Appendix B**

3 **Major Subdivision Submission Requirements**

4 **Preliminary Review**

5 A. **General submission parameters**~~Preliminary Plan Maps and Information~~

6 ~~The Preliminary Plan shall be submitted in~~ An application for preliminary review of a
7 ~~Major Subdivision shall consist of fourteen (14) sets of plans~~ fifteen (15) copies of one or
8 ~~more maps or drawings which may be printed or reproduced on paper with all dimensions~~
9 ~~shown in feet or decimals of a foot, drawn to a scale of no larger than 1 inch equals forty~~
10 ~~(40) feet to the inch and supporting materials;~~ drawings. The size of the plan sheets
11 ~~submitted to the Planning Board shall be no larger than twenty-four not to exceed (24)"~~ x
12 ~~thirty-six (36)" inches. (Revised eff. 12/10/03)~~ A digital copy of the complete
13 ~~application shall also be made available upon request.~~

14 **B. List of submission items.**

15 ~~The application for preliminary approval of a major subdivision shall include all~~ All
16 ~~plans shall be accompanied by the following information.~~ Information that must be
17 ~~shown on a plan is in bold type.:~~

18
19 1. Right, Title or Interest. Evidence of right, title or interest in the site of the proposed
20 subdivision.

21
22 2. Name of Subdivision/Applicant. **Proposed subdivision name** ~~or identifying title;~~
23 ~~the name of the Town, and evidence of right, title or interest in the site of the proposed~~
24 ~~subdivision.~~ 2. — **nName and address of record owner and, applicant; names of**
25 **adjoining property owners; and designer of Preliminary Plan.** 3. — **Date** date of
26 **plan submission, true north point and graphic map scale.**

27
28 3.4. Survey. **A standard boundary survey of the site giving complete descriptive**
29 **data by bearings and distances, made and certified by a licensed land surveyor;**
30 **a copy of the deed for the property to be developed, as well as copies of any**
31 **easements, restrictions or covenants; a plan showing the number of the lot,**
32 **conceptual dimensions of area and building envelope of each proposed lot**
33 **sufficient to demonstrate minimum compliance with zoning requirements;**
34 **existing easements; building lines pertaining to the proposed subdivision and to**
35 **the adjacent properties; Number of acres within the proposed subdivision,**
36 **location of property lines, existing easements, buildings, watercourses and other**
37 **essential existing physical features.** and the numbering of all subdivision lots; 13.
38 — Deed reference and map of survey of tract boundary made and certified by a
39 registered land surveyor, tied into established reference points. Deed restrictions, if
40 any, shall be described. 15. — The proposed lot lines with dimensions, area and
41 building envelopes. 16. — The location of temporary markers adequate to enable the
42 Board to locate readily and appraise the basic layout in the field.

1
2 ~~5. Location location mMap, showing the relative location of the proposed project in~~
3 ~~relation to surrounding neighborhoods or areas of Town; sufficient data to~~
4 ~~determine readily the location, bearing and length of every lot line and boundary~~
5 ~~line and to reproduce such lines upon the ground.~~
6

7 ~~6. The names of all owners of record of adjacent acreage.~~
8

9 4. Water Pollution Evaluation.

10
11 a. Topography. 11. — **Contour lines at intervals of two (2) feet or at such**
12 **intervals as the Planning Board may require, based on United States**
13 **Geological Survey datum and referred to mean sea level.**
14

15 b. Surface drainage. **Surface drainage patterns including drainage channels and**
16 **watershed areas;** the slope of the land and its effect on effluents; the availability
17 **and condition of streams used for disposal of effluents; an evaluation of**
18 **applicable state and local health and water resource rules and regulations.**
19

20 c. Soils. 12. — **A soils report identifying the soils boundaries and names in**
21 **the proposed development with the soils information superimposed upon the**
22 **plot plan in accordance with the USDA Soil Conservation Service National**
23 **Cooperative Soil Classification.** ~~The Board may require a high intensity soil~~
24 ~~survey which will identify changes in soils conditions down to one eighth acre. A~~
25 ~~lot by lot soils suitability determination for housebuilding with septic sewage~~
26 ~~disposal may also be required by the Planning Board.~~
27

28 d. Air. Description of any air emissions not normally included in residential
29 construction and use activities.
30

31 5. Potable Water. Confirmation of a clean and adequate supply of water to serve the
32 subdivision; 8. — **The the location and size of any existing or proposed sewers**
33 **and water mains on the property and adjacent water lines that will provide**
34 **water supply for the property to be subdivided, as well as proposed connections**
35 **to water systems; nearest hydrant; where public water is not to be provided, an**
36 **alternative means of a clean and adequate supply shall be shown.** 5.
37

38 — ~~Written evidence of an adequate supply of domestic water, in the form of (i)~~
39 ~~approval by the Portland Water District, (ii) approval by the appropriate state agency~~
40 ~~of any proposed central water supply system, or (iii) approval by a registered Maine~~
41 ~~engineer if individual wells are to be used for building sites, in which latter case the~~
42 ~~board may also require reports by the appropriate state agency of the results of all~~
43 ~~water quality tests;~~
44

45 6. Erosion. A soil erosion and sediment control plan shall be prepared and certified by a
46 professional geologist or professional engineer.

1
2 **7. Traffic.** ~~10. Location, widths and names and present and proposed widths~~
3 **of existing, filed and proposed roads;** ~~a traffic study evaluating the capacity of~~
4 ~~adjacent roads to safely accommodate the anticipated traffic generated by the~~
5 ~~proposed subdivision, including an assessment of the likelihood of cut-through traffic,~~
6 ~~efforts to provide for road connectivity, and applicability of the Maine Department of~~
7 ~~Transportation Regulations, highways, easements, building lines, alleys, parks and~~
8 ~~other public open spaces both within and abutting the subdivision. Grades and road~~
9 ~~profiles of all roads, sidewalks or other public ways proposed by the applicant shall~~
10 ~~be shown.~~

11
12 **8. Sewage Disposal. All on site public or shared sewage facilities;** ~~9. If~~
13 ~~individual or collective private sewage disposal system(s) is (are) proposed, the~~
14 ~~location and results of tests to ascertain subsurface soils and ground water~~
15 ~~conditions, which shall be signed and numbered by a licensed site evaluator. These~~
16 ~~results shall be submitted on an a completed HHE 200 form or other subsurface~~
17 ~~wastewater design for every lot not served by public sewer. 6. Written evidence of~~
18 ~~(i) the availability of public sewage service for some or all of the lots; or (ii)~~
19 ~~compliance with the clustered sewer system provisions of Chapter 15, review by the~~
20 ~~Town Engineer, receipt of a letter from the Maine Department of Human Services,~~
21 ~~and written approval of the local plumbing inspector; or (iii) municipal approval of~~
22 ~~the proposed sewage disposal systems, to be designed and installed in compliance~~
23 ~~with the Town Sewer Ordinance, and which shall require the review and approval by~~
24 ~~the Town Engineer and the building inspector of the subsoils land of said sewage~~
25 ~~disposal arrangement; and~~

26
27 **9. Solid Waste Disposal. Demonstration of adequate capacity for disposal of**
28 **construction and solid waste to be generated by the subdivision.**

29
30 **10. Aesthetic, cultural and natural information. Location of scenic, unique natural,**
31 **farmland, parkland, historic and significant wildlife habitat areas located on or**
32 **adjacent to the proposed subdivision, as well as supporting documentation. 18.**
33 ~~—The location of all natural features or site elements to be preserved~~

34
35 **11. Local regulations. The boundaries and designations of zoning districts;** ~~7. The~~
36 **applicable space standard and setback provisions of the Zoning Ordinance, and**
37 **evaluation of the proposed subdivision's compliance with applicable provisions**
38 **such as Open Space Zoning (Sec. 19-7-2),** ~~applicable to the area to be subdivided~~
39 ~~and any zoning district boundaries affecting the subdivision.~~

40
41
42 **12. Financial and Technical Capability. 23.** ~~Statement of Technical and Financial~~
43 ~~Capability, including a list of the applicant's development consultants, a description~~
44 ~~of all prior development projects, and a letter of firm financial commitment from a~~
45 ~~bank or other source of financing. In the case where the applicant asserts that public~~
46 ~~disclosure of confidential financial information may prove detrimental to the~~

1 applicant or the project, the applicant may substitute a recommendation from the
2 Town Manager that the applicant has adequate financial capability to complete the
3 project.

4
5 13. Surface Waters. Location of any portion of the subdivision in the Shoreland
6 Zoning; identification of the normal high water line; assessment of how water
7 quality will be impacted by anticipated discharge from the subdivision.

8
9 14. Ground Water. As assessment of how the proposed subdivision will impact
10 groundwater resources.

11
12 15. Floodplain. Location of any portion of the subdivision in the floodplain;
13 assessment of how construction in the floodplain will comply with the Town of Cape
14 Elizabeth Construction Code, Chapter 6, Floodplain Ordinance.

15
16 16. Wetlands. The boundaries of all wetlands in accordance with the Zoning
17 Ordinance; an assessment of how any alterations of wetlands will comply with the
18 Town of Cape Elizabeth Zoning Ordinance, Chapter 19, Sec. 19-6-9.

19
20 17. Stormwater/Phosphorus. 14.——A conceptual surface drainage plan or stormwater
21 management plan, showing preliminary design of all facilities and conveyances
22 necessary to meet the stormwater management standards as set forth in this
23 Ordinance. Where the subdivision includes or abuts Great Pond, an assessment of
24 phosphorus loading amounts and impacts on Great Pond.

25
26 18. Liquidation Harvesting. Identification of any portion of the subdivision where
27 timber has been harvested in violation of Title 12, section 8869, subsection 14.

28
29 19. Landscaping. An inventory of existing vegetation to be preserved; methods of
30 preserving vegetation to be used during construction; a conceptual landscaping
31 plan. 22. —A grading and landscaping plan including natural features to be preserved.

32
33
34 20. Open Space. Designation on the plan of the land to be permanently protected as
35 open space; calculation of the open space provided to meet the Open Space
36 Impact Fee (Sec. 16-3-1(t)); location of easements; fee interest or easement deeds
37 of open space to be conveyed to the Town or otherwise conserved.

38
39 21. Utilities. Evidence of the capacity to provide electrical and telephone facilities.

40
41 22. Phasing. A concept phasing plan, if the project will be phased.

42
43 23. Related Information. Any other data as determined by the Planning Board to ascertain
44 compliance with this Ordinance.

1 | 24. Community Impact Analysis. The Planning Board may require the applicant to
2 | conduct a community impact analysis which will consist of the following
3 | demographic features.

4 |
5 | a. Demographic Description. The analysis must identify the demographic market the
6 | project intends to serve, including:

- 7 | (1) type of family;
- 8 | (2) average family size;
- 9 | (3) number and ages of children; and
- 10 | (4) anticipated time period to fill all units or lots.

11 |
12 | Associated data, such as anticipated income levels, type of employment, and
13 | projected housing costs may also be presented to support projections associated with
14 | the above demographic description.

15 |
16 | b. Community Impact Analysis. Utilizing the above demographic data, the applicant
17 | shall conduct analyses of the following:

- 18 | (1) Estimated impact of traffic systems, including the impact of projects trips on
19 | flow characteristics and the impact of traffic on the immediate, existing road
20 | structures;
- 21 | (2) Estimated impact on the school system;
- 22 | (3) Estimated impact on public safety providers;
- 23 | (4) Estimated impact on the public works department, including solid waste
24 | disposal;
- 25 | (5) Estimated impact on existing storm water management systems including
26 | flow and water quality;
- 27 | (6) Estimated impact on the recreation resources and provision of methods to
28 | meet proposed needs; ~~4+~~
- 29 | (7) Estimated impact on wildlife habitat areas;
- 30 | (8) Impact on the stated goals and objectives of the Comprehensive Plan; and
- 31 | (9) Any other study deemed appropriate by the Planning Board.

32 |
33 | Once these analyses have been completed, the applicant shall present this information
34 | and impact assessments to the Planning Board for its review and comment.

35 | **~~B. Final Plan Maps and Information~~**

36 | **Final Review**

37 | ~~A. General submission parameters. Same as for Preliminary Review. Application for~~
38 | ~~final approval shall be accompanied by fifteen (15) copies of final subdivision plans,~~
39 | ~~drawn to scale, reproduced in the size and manner of preliminary plans, showing:~~

40 |
41 | **B. List of submission items**

42 | 1. Preliminary Approval. All information required to be shown on the preliminary plans,
43 | with all amendments required by the Planning Board and other reviewing agencies

1 and those suggested by the Planning Board and adopted by the applicant, ~~except~~
2 ~~topography unless changed from the preliminary plans and except soils data, in~~
3 ~~accurate final form with distances to an accuracy of one foot in 5,000 feet; and further~~
4 ~~augmented as follows:~~

5
6 **2. Survey. Final plan showing the number of the lot, final calculations of lot area,**
7 **property line dimensions and building envelope for each proposed lot.**

8
9 **3. Potable Water. The preliminary plan approved by the Planning Board for water**
10 **supply supplemented to include final design, details and specifications of**
11 **installation and connection to existing water mains.** ~~, culverts, hydrants, and drains~~
12 ~~on the property to be subdivided. This shall show the connections with existing sewer~~
13 ~~or water systems. Where public water and/or sewage is not to be provided, alternative~~
14 ~~means of water supply and sewage treatment and disposal shall be shown.~~

15
16
17 **4. Traffic. The preliminary plan approved by the Planning Board for road access**
18 **and traffic supplemented to include final design, details and specifications of**
19 **proposed roads, driveways as needed, and connections to existing roads.** ~~19.~~

20 ~~— Typical cross sections of the proposed grading for roadways, sidewalks, etc.~~
21 ~~including width, type of pavement, elevations and grades with profiles and cross~~
22 ~~sections drawn by a professional engineer, registered in the State of Maine~~

23
24
25 **5. Sewage Disposal. The preliminary plan approved by the Planning Board for**
26 **public or private cluster sewage system supplemented to include final design,**
27 **details, and specifications of proposed sanitary waste infrastructure and**
28 **connections to public sewer lines.**

29 **6. Local regulations. The preliminary plan approved by the Planning Board**
30 **updated to reflect any changes to how the project complies with local**
31 **regulations.**

32 **7. Financial Capability. Performance guarantee estimate with detail of unit cost and**
33 **quantity for the subdivision, segmented into phases if the proposed subdivision will**
34 **be phased; draft performance guarantee document including issuing agent.**

35 **8. Stormwater/Erosion. The preliminary plan approved by the Planning Board for**
36 **stormwater management and erosion control supplemented to include final**
37 **design, details, and specifications of the proposed stormwater infrastructure and**
38 **any connections to existing stormwater facilities.** ~~20. Preliminary designs of any~~
39 ~~bridges or culverts which may be required.~~

40
41
42 **9. Landscaping. The preliminary plan approved by the Planning Board for**
43 **landscaping supplemented to include final design, details and specifications**

1 including but not limited to a detailed planting plan showing vegetation to be
2 preserved, preservation plan, new planting locations, planting types, quantities
3 and size at time of planting, fencing location, type, size and materials.

4 10. Open Space. The preliminary plan approved by the Planning Board for open space
5 preservation supplemented by draft written conservation restrictions, easement deeds,
6 survey descriptions, and any other documentation. 17.—All parcels of land proposed
7 to be dedicated to public use and the conditions of such dedication. 3.—Proper
8 designation of all spaces to be reserved for or dedicated to the Town or other third
9 party or to be reserved by the applicant,

10
11
12 11. State and Federal permits. 4.—Written evidence of the issuance of all permits,
13 licenses and approvals required for the subdivision from any federal, state or other
14 local agency.;

15 ~~2.—Field survey of the subdivision perimeter complete with courses and distances made~~
16 ~~and certified by a registered land surveyor whose name, number and seal shall be~~
17 ~~shown, with all corners marked by monuments set as prescribed herein and with~~
18 ~~sufficient data to determine readily the location, bearing and length of every lot and~~
19 ~~boundary line and to reproduce such lines on the ground;~~

20
21 12. Conditional Municipal Approval. 7.—Written evidence of (i) the offer and
22 conditional municipal approval by the Town Council of all roads, sewer lines,
23 drainage easements, proposed public open space, recreation land, and other such
24 common areas and facilities proposed to be dedicated to the Town; or (ii) satisfactory
25 agreements or other documents showing the manner in which private roads, sewer
26 lines and systems, drainage ways, open space, recreation land, and other such
27 common areas and facilities are to be maintained. Written agreements of a dedication
28 to a third party other than the Town must also be submitted and deemed satisfactory
29 by the Planning Board.

30
31 138. Phasing Plan. If the subdivision will be constructed in phases, the phasing
32 plan shall show the entire subdivision and every part of the subdivision shall be
33 assigned to a phase. The plan shall also identify the sequence of construction of
34 phases and show how utilities, emergency vehicle access, turnaround space and
35 any other element of the development that will be impacted by phasing will be
36 accommodated for each phase.

37
38 13. Recording Plat. A Subdivision Plat suitable for recording which includes a
39 prominent notation that there shall be no sale of lots, nor issuance of building
40 permits, nor site work commenced until the required performance guarantee
41 has been approved in accordance with Sec. 16-2-6(c) of this Ordinance.16-2-4
42 (e)(7)(A).

Subdivision Ordinance
Appendix C
Road Tree List

The following trees are recommended for planting to meet the road tree requirements. Alternative species may also be acceptable upon approval of the Tree Warden, unless specified by the Planning Board. The list includes the scientific and common tree name, minimum required caliper at the time of planting, expected height at maturity and comments. The comments refer to tree characteristics of water and salt tolerance.

Scientific	Common	Size	Height	Comments*
Acer campestre	Hedge Maple	2"	45'	D,M
Acer saccharum	Sugar Maple	2"	80'	WD
Acer pseudoplatanus	Planetree maple	2"	60'	WD,H
Acer rubrum	Red Maple Cultivars	2"	60'	W,M
Betula alleghaniensis	Yellow Birch	2"	50'	W
Betula nigra	Heritage River Birch	2"	60'	W
Carpinus caroliniana	American Hornbeam	2"	30'	W
Cercidiphyllum japonicum	Katsura	2"	60'	W
Chionanthus virginicus	Fringetree	2"	30'	W
Cladrastus kentuckea	Yellowwood	2"	60'	W
Corylus colurna	Turkish Filbert	2"	50'	D
Crateagus spp.	Hawthorne	2"	30'	D
Ginkgo biloba	Maidenhair Tree	2"	60'	D,M
	Cultivars			
Maackia amurensis	Maackia	2"	40'	W
Nyssa sylvatica	Tupelo	2"	60'	W
Platanus acerfolia	London Plane	2"	75'	W
Quercus bicolor	Swamp White oak	2"	55'	W
Quercus rubra	Red Oak	2"	75'	D
<u>Quercus spp.</u>	<u>Other oak species as approved by Tree Warden</u>	<u>2"</u>		
Sorbus alnifolia	Korean Mountain Ash	2"	35'	D,M
Syringa reticulate	Japanese Tree Lilac	2"	30'	D,M
Zelkova serrata	Zelkova	2"	50'	W
<u>Native species</u>	<u>as approved by Tree Warden</u>	<u>2"</u>		

* W= Wet, D=Dry, WD=Well Drained, M=Moderate Salt Tolerance and H= High Salt Tolerance

All trees shall be planted in accordance with the Planting Specifications of the Cape Elizabeth Comprehensive Street Tree Plan.

1
2
3
4

Appendix D
Turnaround Designs
Page 1 of 2

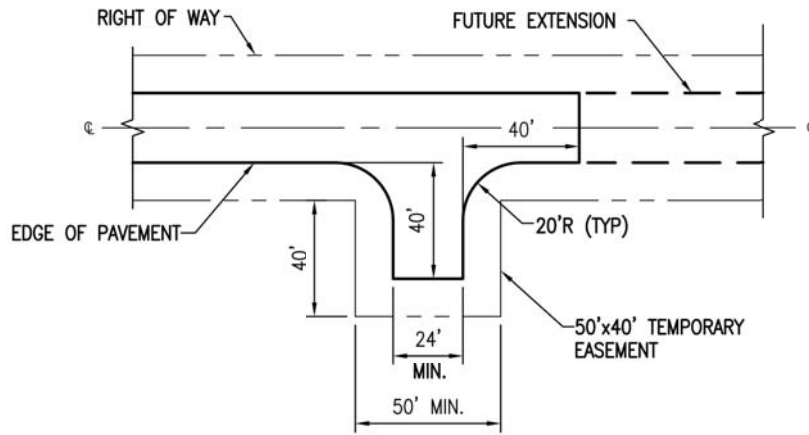

ALTERNATE #1

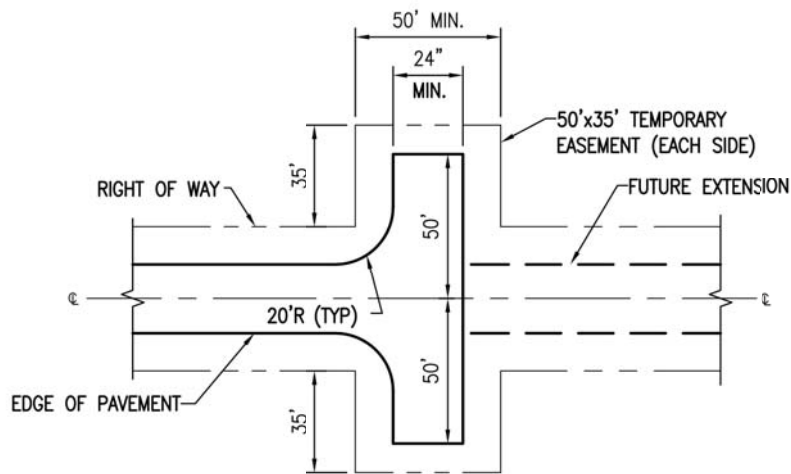

ALTERNATE #2

MINIMUM DIMENSIONS
TURN-AROUNDS
NOT TO SCALE

5
6

1
2
3
4
5
6

Appendix D
Turnaround Designs,
Page 2 of 2

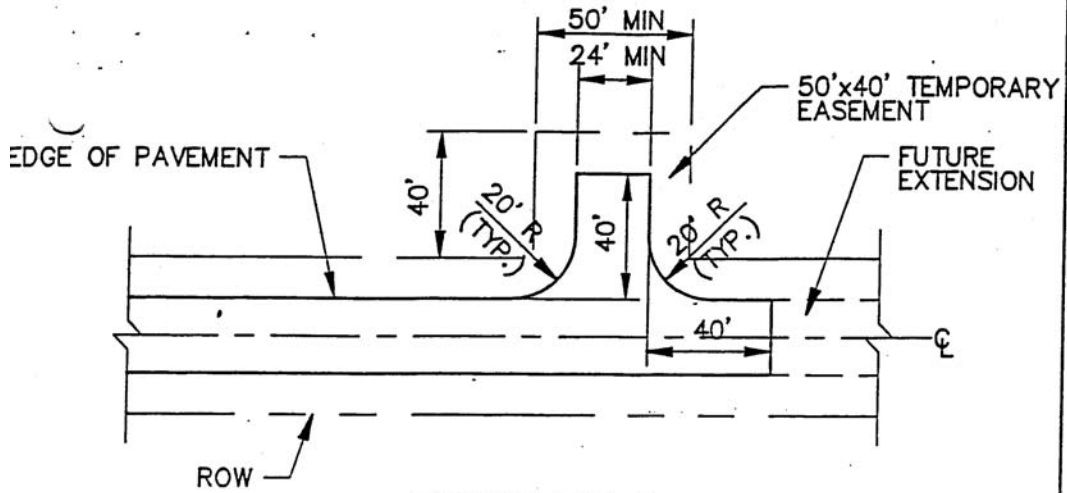

ALTERNATE 1

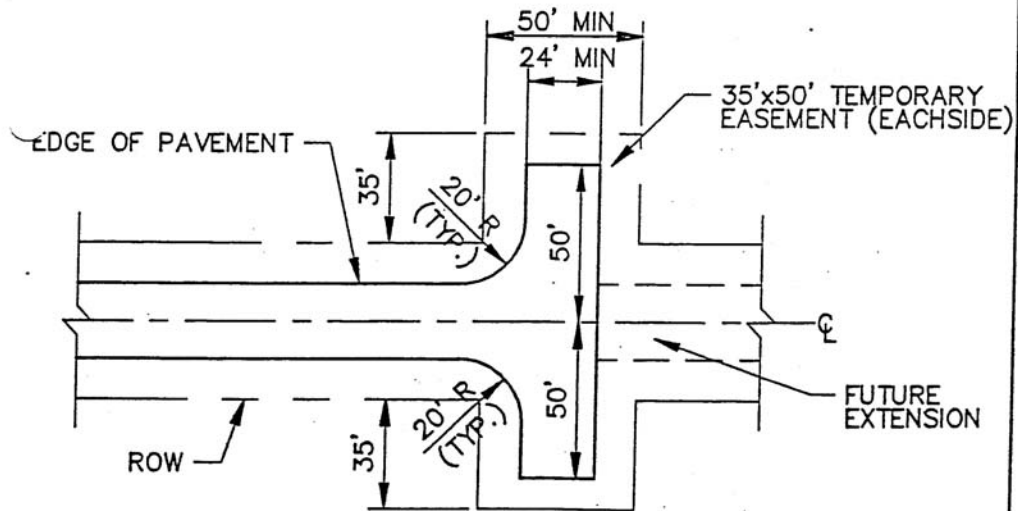

ALTERNATE 2

MINIMUM DIMENSIONS FOR TURN-AROUNDS
NOT TO SCALE

8
10

1
2
3
4

Appendix E
Road Cross Sections
Local
Road

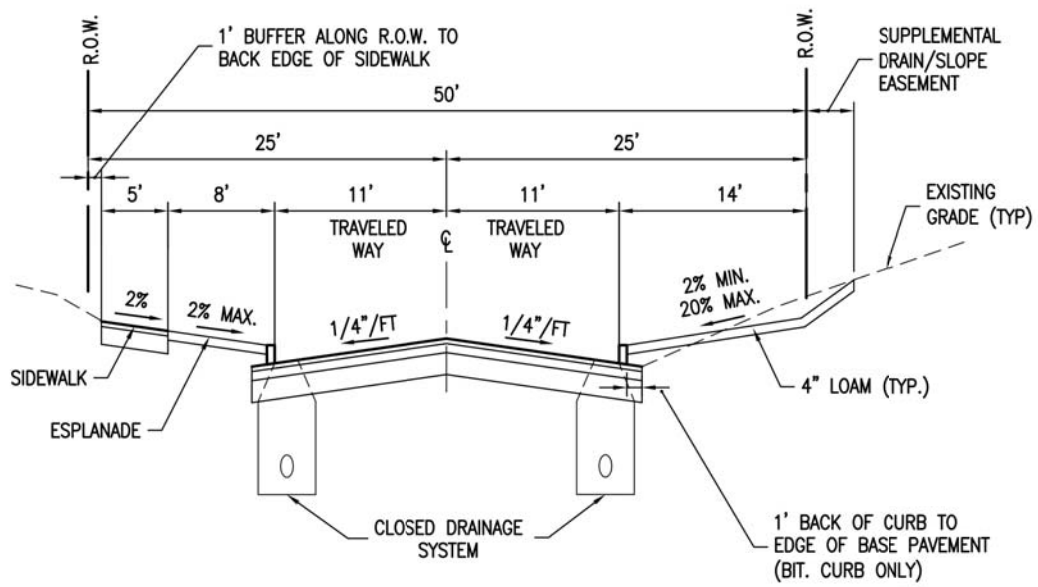

NOTE:
SEE ROAD CLASSIFICATION STANDARDS TABLE

LOCAL ROAD
NOT TO SCALE

5
6
7

1
2
3
4
5

Appendix E
Road Cross Sections
Feeder
Road

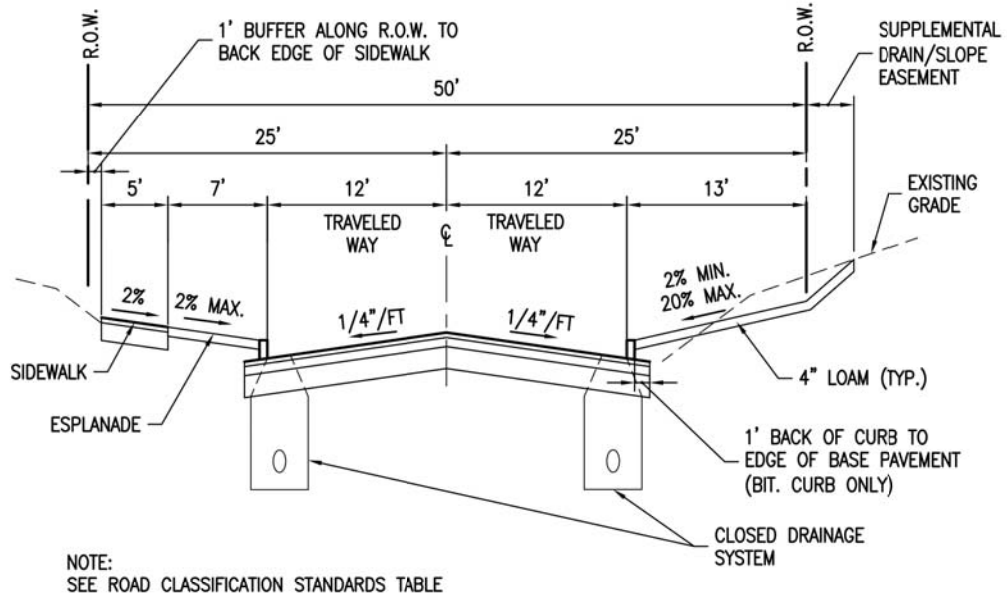

FEEDER ROAD
NOT TO SCALE

6
7

1
2
3
4
5
6
7
8

Appendix E
Road Cross Sections
Collector Road

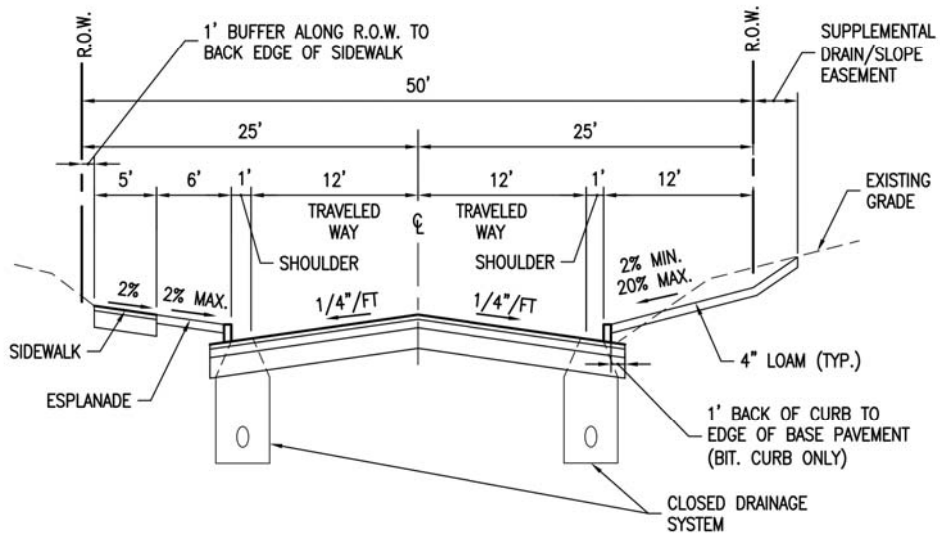

NOTE:
SEE ROAD CLASSIFICATION STANDARDS TABLE

COLLECTOR ROAD
NOT TO SCALE

9

1
2
3
4
5
6
7
8

Appendix E
Road Cross Sections
Rural Connector

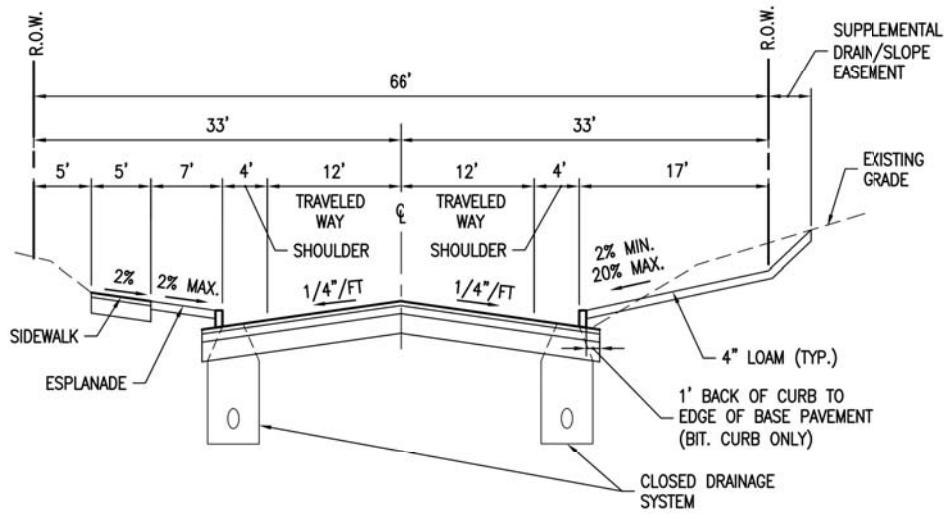

NOTE:
SEE ROAD CLASSIFICATION STANDARDS TABLE

RURAL CONNECTOR ROAD
NOT TO SCALE

9
10
11

1
2
3
4
5
6
7
8

Appendix E
Road Cross Sections
Arterial Road

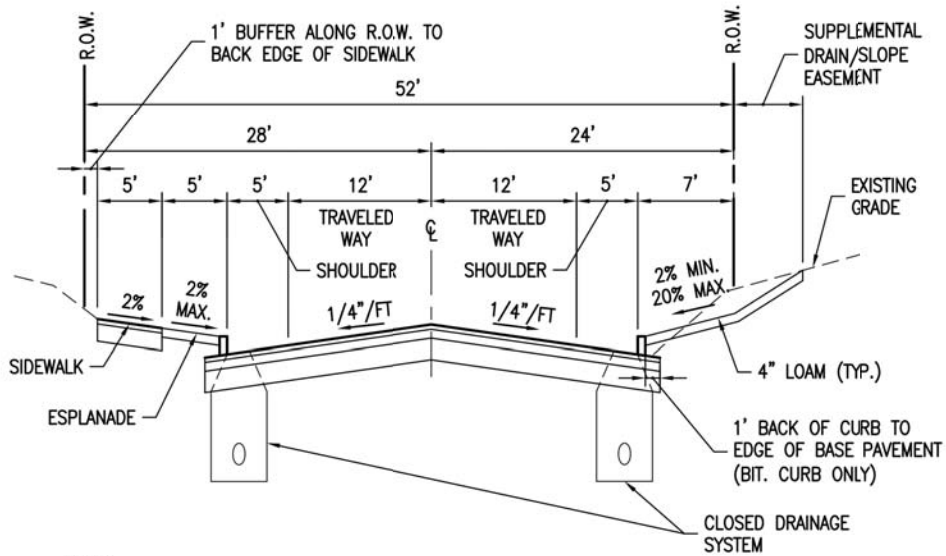

NOTE:
SEE ROAD CLASSIFICATION STANDARDS TABLE

ARTERIAL ROAD
NOT TO SCALE

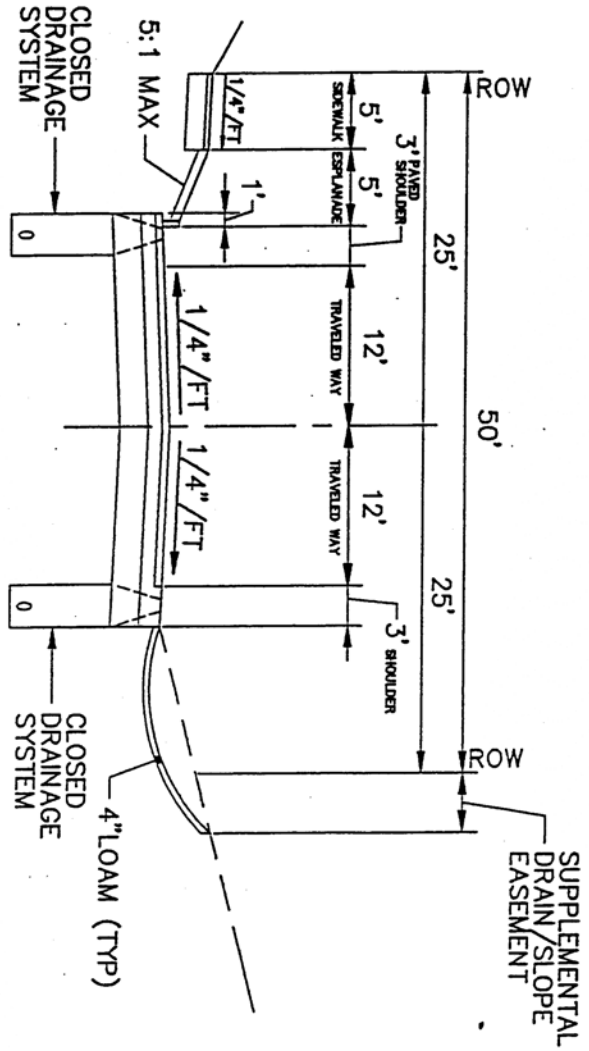

FEEDER
 NOT TO SCALE